

SEVENTH YEAR OF SERVICE

# RADIO ENGINEERING

Vol. VII

OCTOBER 1927

Number 10

## Radio Industry Standards

A single set of Standards for the Radio Industry to be established by RMA and NEMA

## Exponential Horn Speakers

The mechanical and electrical design of the Horns and the Speaker Units

## The Cathode Ray Oscillograph Tube

How the Service Man can employ it for testing purposes

## The Gaseous Conduction Rectifier

An interesting story of its development

## The "Super-Hilodyne" Circuit

A new system employing a selective push-pull tuning circuit and an untuned intermediate amplifier

## Aeroplane Radio Equipment

Technical considerations covering the selection and installation of radio equipment for long distance Aeroplane flights

## Radio Developments of the Year

A report of the Fourth Annual Radio World's Fair



20¢ per Copy

Sold Only by Subscription—

\$2.00 per Year

The Technical Magazine of the Radio Industry

[www.americanradiohistory.com](http://www.americanradiohistory.com)

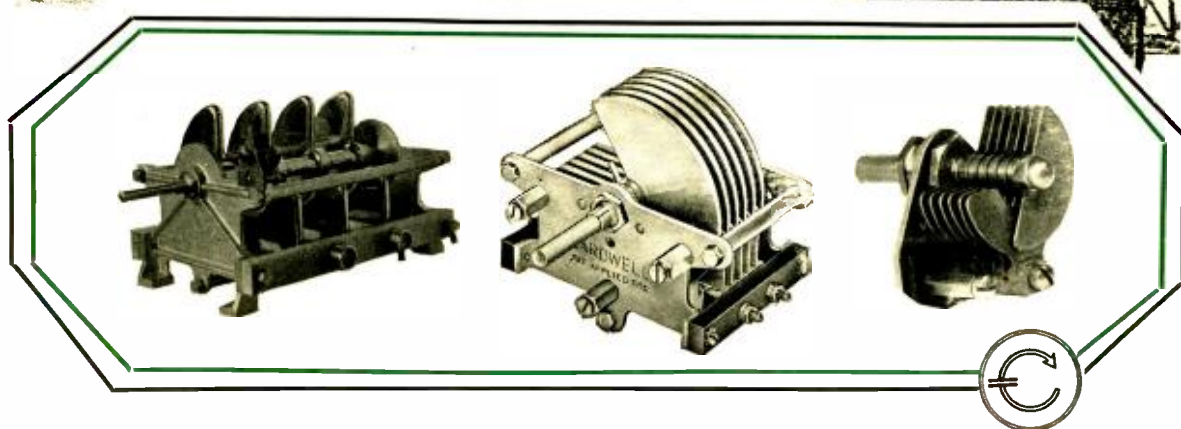

IF you want your set to stand up for years,—YOU NEED **STRENGTH!**

IF you don't want to have to replace condensers,—YOU NEED **STRENGTH!**

IF you want "single-control" to stay "single-control",—YOU NEED **STRENGTH!**

In short—if you are turning out GOOD sets—YOU MUST HAVE **STRENGTH!**

And in **CARDWELL CONDENSERS** you *have* **STRENGTH**. Specified by Army and Navy Engineers—used by R. C. A., Westinghouse, General Electric—their **STRENGTH** and **UNIFORMITY** are unequalled.

From the tiny "Balancet" to the huge Broadcasting Station condensers, *there is nothing comparable* to the **CARDWELL CONDENSER**.

**The Allen D. Cardwell Mfg. Corp.**  
**81 Prospect Street, Brooklyn**  
**New York**

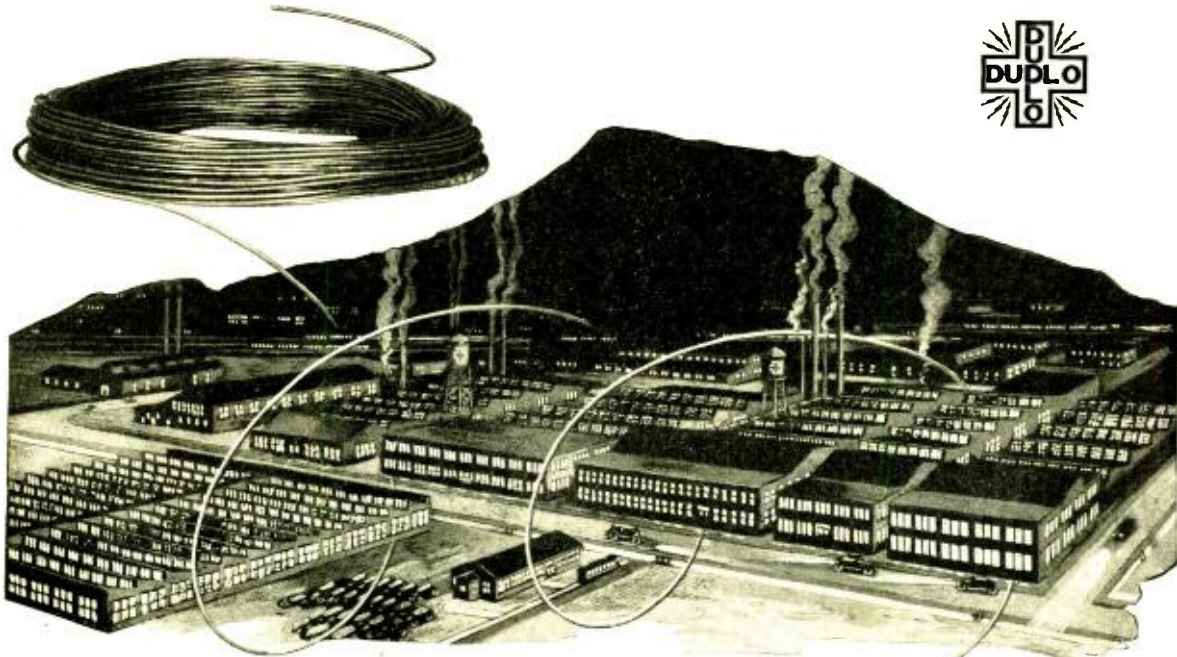

## From Copper Rod to Magnet Wire and Coils!

The Dudlo production cycle is complete, controlling all materials and processes from rod to coil.

Beginning with the bare copper rod, the drawing, annealing, insulating and winding is completed in the Dudlo factories, under scientific, progressive inspection. This system of inspection prevents hidden flaws and insures uniform high quality.

The bare wire is drawn and then insulated with enamel, cotton, silk, or any combination of the three, to standard specifications or to meet special requirements for the Coil Winding Department.

Specializing solely in the production of Magnet Wire and Coils—with a wide variety of experience with wire and coil problems—with every resource of specially designed machinery and skilled engineers, Dudlo gains greater efficiency, greater flexibility and thus renders greater service to the electrical trade.

So urgent is the demand for Dudlo products that the plant, though recently enlarged, is kept busy day and night.

No coil is any better than the wire in it and no electrical apparatus is any better than its coil. The real competition is always quality. Manufacturers of electrical apparatus stand or fall upon the sustained and uninterrupted service their products give.

It is the part of wisdom, therefore, to use the best Magnet Wire and Coils. The electrical world increasingly acknowledges Dudlo's high and dependable quality.

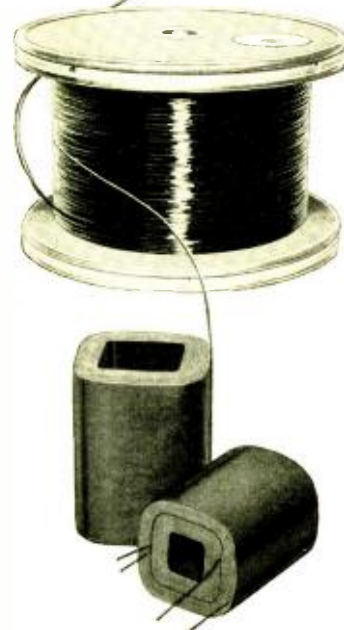

# DUDLO

**DUDLO MANUFACTURING CORPORATION, FORT WAYNE, INDIANA**

56 EARL STREET  
NEWARK, N. J.

160 NORTH LA SALLE STREET  
CHICAGO, ILL.

4153 BINGHAM AVE.  
ST. LOUIS, MO.

274 BRANNAN ST.  
SAN FRANCISCO, CALIFORNIA

# RADIO ENGINEERING

52 Vanderbilt Avenue, New York, N. Y.

EDITED BY M. L. MUHLEMAN

Associate Editor, John F. Rider

Associate Editor, Harry G. Ciss

Vol. VII

OCTOBER, 1927

Number 10

## EDITORIAL

**I**N the Editorial appearing in the July, 1927 issue of RADIO ENGINEERING, we aired our convictions regarding the present state of the radio industry, especially in connection with the existing double set of standards. It was pointed out that no good could possibly come from an arrangement so obviously an instrument for creating confusion and that RADIO ENGINEERING was firmly convinced that the National Electrical Manufacturers Association and the Radio Manufacturers Association should do everything in their power to effect some scheme whereby a single set of standards would serve both organizations.

During the R. M. A. Convention held in Chicago, it was decided that, though the R. M. A. had a membership of ten times that of the Radio Section of N. E. M. A., it would not take any steps that would in any way be instrumental toward bringing about additional confusion in standards. Furthermore, it was openly announced, pending a meeting of the executives of both organizations, that the R. M. A. would not publish any new standards—it would simply continue any necessary committee work. This showing of respect for an older organization is to be commended and the directors of the R. M. A. are to be congratulated for being true to their word. Likewise, the Radio Section of N. E. M. A. is to be commended on its stand as it is true that its set of standards is so firmly entrenched by the group using them that any unpremeditated move to abolish immediately or revise a part or a whole would bring about more confusion.

RADIO ENGINEERING believes that the most logical way in which to relieve the strain is through the formation of a joint committee to work in common towards setting up a single group of standards which will be more representative of the entire industry than of any particular organization. These Radio Industry Standards would consist of a code made up by reviewing the old R. M. A. standards, the N. E. M. A. standards, and any other acceptable proposals offered. Such independent radio standards, free of trade associations, would certainly have a good influence on the entire industry and would abolish much, if not all, of the present confusion.

A vast majority in both the N. E. M. A. and R. M. A. organizations have been interested in a single set of industry standards. The Board of Directors of the R. M. A. have signified their willingness to alter, or drop altogether, the present R. M. A. standards if something definite in the way of independent industry standards can be worked out. The Board of Governors of the N. E. M. A. are probably as willing to concede to beneficial alterations.

RADIO ENGINEERING advocates any move, in connection with the formation of Radio Industry Standards, which will abolish the present confusion.—M. L. MUHLEMAN, *Editor*.

## CONTENTS

The Modern Exponential Horn Type Loud Speaker.....	967
<i>By Paul G. Andres</i>	
Aeroplane Radio Equipment.....	970
<i>By Bert E. Smith</i>	
Short Wave Transmitter Shows Characteristics of Light Propagation.....	973
Report of the Fourth Annual Radio World's Fair.....	974
Frequency Standardization Work.....	975
<i>By W. A. Ford</i>	
Little Known Facts About the Well-Known Gaseous Rectifier.....	976
<i>By Austin C. Lescarboursa</i>	
The "Super-Hilodyne" Circuit.....	978
<i>By Fred. A. Jewell</i>	
The Photo-Electric Cell, Part II.....	980
<i>By Dr. Robert C. Burt</i>	
The Cathode Ray Oscillograph Tube.....	982
<i>By John F. Rider, Associate Editor</i>	
The Use of Measuring Equipment, Part III.	987
<i>By E. W. D'Arcy</i>	
Methods of Controlling Volume.....	989
<i>By Charles Golenpaul</i>	

## Departments

Constructional Developments.....	990
News of the Industry.....	995
New Developments of the Month.....	998
Vacuum Tube Directory.....	1008
Buyers' Directory.....	1020
Index to Advertisers.....	1022

Published monthly by RADIO ENGINEERING MAGAZINE, Inc. Publication office, Lyon Block, Albany, New York, Editorial and business offices, 52 Vanderbilt Ave., New York, N. Y. Printed in U. S. A. Yearly subscription \$2.00 in U. S. and Canada; ten shillings in foreign countries. Entered as second class matter at the postoffice at Albany, New York, January 9, 1925, under the act of March 3, 1879.

New York advertising office, B. S. Davis, 52 Vanderbilt Ave.

# “Batteries can't be beat for plate power”

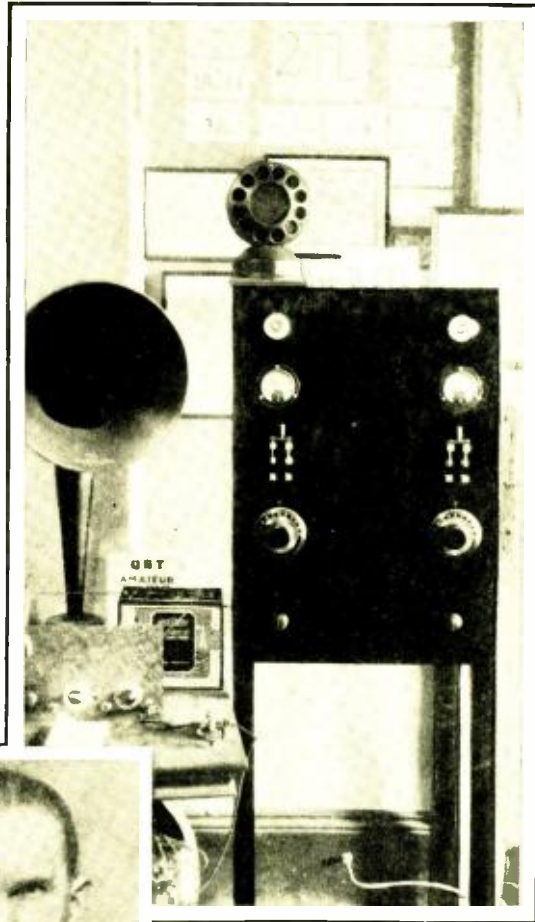

Station 2TL  
Port Jervis, N. Y.  
Mr. Jos. W. GIBBONS



WHEN you put on the cans and hear the buzzes, rattles and jazz of raw or partly rectified AC; and when in the midst of the racket you suddenly come on a smooth, pure DC note, strong, steady, sharp, and easily readable—that's the station you start to copy.

How about yourself, OM? Are you giving the other fellow the sort of sigs you prefer to read? Eveready Layerbilt “B” Batteries are putting on the air every night the prettiest DC notes you can hear. And as for DX—well, just read this, from Jos. W. Gibbons, 2TL, Port Jervis, N. Y.: “Short waves travel far on low power . . . 7PH of Everett, Washington, heard my signals when using 90 volts of Eveready ‘B’ Battery for plate power.” 2TL adds: “Having followed up radio since the old spark days, I find that Eveready

Batteries have stood the test of time on both transmitter and receiver. The old timers know that ‘B’ batteries can't be beat for plate power for a good report.”

As far as we have been able to discover, the Eveready Layerbilt “B” Battery No. 486 is the longest-lasting, most economical “B” battery ever built, for short wave transmitters and receivers, as well as for BCL sets.

NATIONAL CARBON COMPANY, INC.  
New York San Francisco  
*Unit of Union Carbide and Carbon Corporation*

*Tuesday night is Eveready Hour Night—9 P. M., Eastern Standard Time, through the WEAf network*

# EVEREADY

## Radio Batteries

*-they last longer*

# POWER!

*Listen,* You, engineers, production men, technicians, professional set builders—whether you are talking short-wave transmission or just good broadcast reception, you are today talking in terms of POWER. That's the keynote of radio progress in all directions. No longer are we content with mere microwatts or microamperes in our circuits. And not every variable resistor in sight will do the bigger job now called for when it comes to handling honest-to-goodness energy. As usual, however, your old friend CLAROSTAT has kept in step with developments, and here is the answer.



**THE POWER  
CLAROSTAT**

A husky variable resistor for handling real power. In several turns of knob, it covers wide range. Handles up to 40 watts of energy. Obtainable in three resistance ranges—0 to 10 ohms for line-voltage and primary group voltage control; 25-500 ohms for series-connected filament control with B-voltage tap resistances in series; 200-100,000 ohms for series-connected filament control, with or without shunted fixed resistance. And there are countless other uses. Price \$3.50.

Five years of persistent, concentrated and specialized effort to develop a satisfactory device that would provide the *convenience* of the variable resistor and the *reliability* of the fixed resistor, have gone into the development of the Clarostat design. The well-known Standard type has found wide application in radio B-eliminators, receiving sets, and in the smaller radio transmitters. And the same sound design, on a necessarily larger scale, has made the Power Clarostat possible! So much for today. But when larger variable resistors are required, Clarostat will be the first to build them.

*The fact that others have seen fit to copy the Clarostat and to offer something "just as good as the Clarostat" speaks for itself.*

*Write for our literature on the use of the Power and Standard Clarostats. Ask your local radio dealer to show you these improved variable resistors.*



**THE STANDARD  
CLAROSTAT**

Too well known to require lengthy introduction, this device has more applications than ever. It is the ideal B-voltage tap control, providing the precise voltage for each circuit and for any type of tube. In several turns of its knob, it offers a universal resistance range of from practically 0 to 5,000,000 ohms, with a current-carrying capacity of 20 watts. The Clarostat is noiseless, non-packing, foolproof and indestructible within its working capacity. Price \$2.25.



**AMERICAN MECHANICAL LABORATORIES, INC.**

*Specialists in Variable Resistors*

281-287 NORTH SIXTH STREET :: :: BROOKLYN, N. Y.

# CLAROSTAT

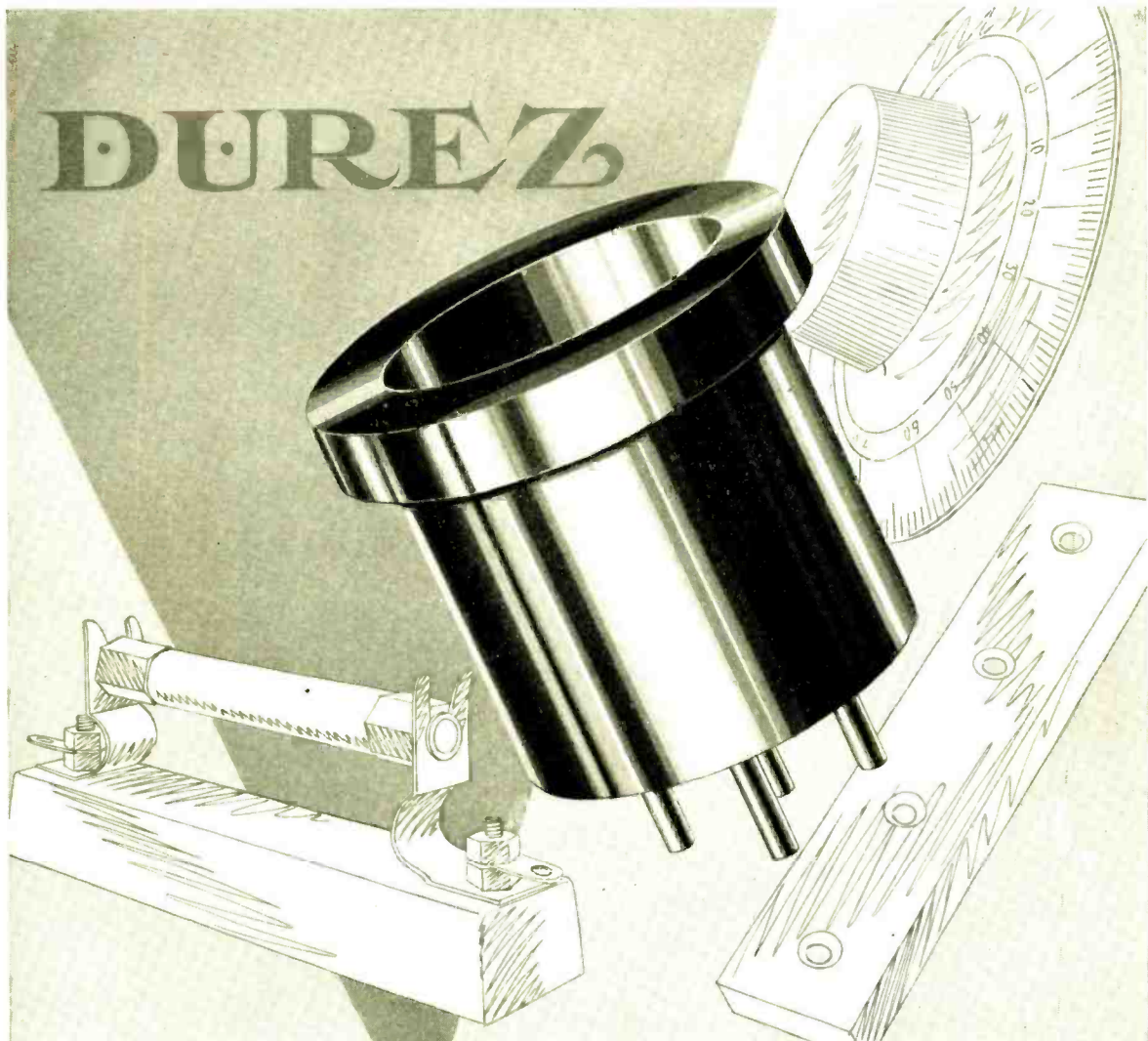

## DUREZ—molded parts with high dielectric strength and permanent luster—DUREZ

DUREZ molded parts have a rapidly increasing range of application in the radio, automotive and electric appliance industries wherever a combination of high dielectric strength and excellent appearance are essential. Durez is electrically non-conductive, non-inflammable and is resistant to heat. It has a permanent high luster after molding, and neither wear, age nor deteriorating agencies affect its attractiveness. The surface will not crack or check.

Durez molds with perfect accuracy. It duplicates exactly the smallest detail of intricate design.

Complex parts can be made rapidly in a single operation, and the high mechanical strength of Durez makes thin section molding entirely practical.

Radio panels of Durez molded with ornamental inscriptions and embossments present a handsome appearance. The strength of Durez permits the extensive use of holes, slots and metal inserts in molding panels and sub-panels. Dials, instrument cases and tube bases are made quickly, durably and beautifully of Durez.

Durez is speeding the production and improving the products

of many industries. Use the facilities of the Durez laboratory to determine its place in your process. Counsel and investigation without obligation.

Molded samples of Durez and complete data sent on request. Specify use and color.

**GENERAL PLASTICS**  
INCORPORATED  
NORTH TONAWANDA, NEW YORK  
CHICAGO NEW YORK SAN FRANCISCO



SEND FOR THE BOOKLET, "DOING IT WITH DUREZ"



**A. C. Amplifier  
Type M-26**  
(226)

Fil. Volts	1.5
Fil. Amp.	1.05
Plate Volts	90-135
Not to Exceed	180

List Price  
**\$3.00**



**A. C. Detector  
Type N-27**  
(227)

Heater Volts	2.5
Heater Amps.	1.75
PLATE VOLTS	45
As Detector	90-135
As Amplifier	180
Not to Exceed	

List Price  
**\$6.00**

# Announcing A. C. Tubes

ALTERNATING CURRENT

THE new M-26 and N-27 tubes are tubes using raw A.C. on the Filament or Heater and can be used in any set specifying these types. The M-26 is used in the radio and audio frequency stages and has a standard base. The N-27, of the separate heater type is used as a detector or amplifier and has a five-prong base. These tubes will give superior results and maximum useful life in any set designed to use A.C. tubes of this type.

*Write for particulars.*

C. E. Mfg. Co. Inc., Providence, R. I., U. S. A.  
Largest Plant in the World Making  
Radio Tubes Exclusively



# E C

## RADIO TUBES

**E C**

**A Tube for  
Every Radio Need**

- General Purpose Tubes
- Special Purpose Tubes
- Power Tubes
- Filament Type Rectifiers
- Gas Filled Rectifiers
- A. C. Tubes

—  
Make a  
Good Receiver  
Better



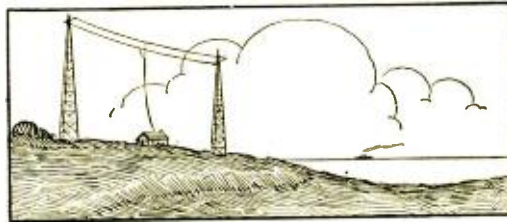

# The Modern Exponential Horn Type Loud Speaker

*Covering the design requirements of horns and speaker units and the importance of perfect mechanical and electrical matching*

By Paul G. Andres\*

## The Air Column

Four points in connection with the construction of the air column come to mind as important in determining the characteristics of such a device. (a) The mathematical design of the rate of expansion of an air column and limiting dimensions. (b) The mechanical construction with respect to reducing the size of the horn. (c) The nature of the walls of the air

the best horn for uniform loading from the very low to the very high frequencies. As mentioned above, exponential horns are not new, although they are constantly "invented" as radio reproducers and heralded with much eclat.

It is interesting to note that long horns offer uniform loading to a small vibrating surface such as a diaphragm, and that further, no undue or pronounced resonances occur when the length of such a horn is sufficiently long enough so as to bring the natural period of the air column below audible frequencies. It is well known that a conical horn has no definite frequency cut-off point while the theoretical exponential horn has such a cut-off point determined by the length of the horn, final bell area and the rate of taper.

In practice however, it is found that such a horn does respond to the very low frequencies. If a horn is designed which has a medium length, that is in the neighborhood of 48 inches or more, the cut-off point is relatively low in the frequency spectrum; but because of the fact that in many cases the harmonics in ordinary musical instruments are practically as strong as the fundamental, the human ear finds much difficulty in discriminating between the true fundamentals and the harmonics. This gives an overall effect of apparently reproducing lower tones than actually exist, although in a comparison of such a medium length horn and a very long horn, the presence of the fundamental is easily detected.

Numerous designs have been worked out in order to condense such a long horn into very small space, resulting in the well known reflex and coiled up types. It is apparent that compensation must be made whenever the horn deviates from the straightaway course, inasmuch as reflections occur at the point of curvature and certain frequencies are greatly modified, depending on the length along the air column where such curvatures occur. These points are receiving much attention in laboratories at the present time, not

THE horn type of loudspeaker has been a simple and efficient reproducer from the early days of train announcing and phonograph reproducing standpoint up to the present time. Some of the early experiments which Comer and others made with respect to electrical transmission of phonograph music over wires and then reproducing this music for domestic use used relatively short horns of a shape approximating an exponential contour. It was found in those days that such a shaped horn gave considerably better results than the straight conical one, but in either case the lower frequencies which, as is well known, carry the most energy in speech, were lost.

The actuating unit was one which used a small diaphragm, a very stiff resonating system and incorporated other factors which gave great sensitivity and response to the higher frequencies, but which in turn also lacked the lower frequencies.

Some of the early forms of radio reproducers were of this general type although the large one in Fig. 1, is an exponential horn 72 inches long designed in 1922. The majority of these horns, however, were relatively short.

The advent of the orthophonic horn, developed by the Bell Laboratories for phonograph use, showed conclusively that it was possible to obtain excellent results from the reproducing standpoint by means of a long horn when used in conjunction with a properly designed actuating unit. Although large horns had been made in laboratories for experimental purposes many years ago, simultaneous development of the unit and horn were necessary before the long horn type of loudspeaker reached the commercial importance it now occupies in the radio industry. Many forms of this type of loudspeaker have been developed but this article will concern itself chiefly with a long horn speaker of unique design and which gives excellent results as a reproducer.

\* Chief Engineer, Temple Inc.



Fig. 3. A giant exponential horn, made in one piece, with an air column ten feet long.

column. (d) The mass inertia of the speaker.

## (a) Mathematical Design

The mathematics of the horn as a sound radiator received much attention many years ago. The late Lord Raleigh, and more recently, Prof. Webster, have laid the mathematical foundation which within recent years has been elaborated to include the many special forms of contour a horn may take. All of these calculations in general make a number of assumptions. One of these assumptions is that the air column is bounded by a straightaway horn. The theory shows that an exponential horn is decidedly better than a conical horn of the same length and terminal dimensions, and that further, it appears that it is



Fig. 1. Some early types of horn speakers. The largest one is an exponential horn 72 inches long, designed in 1922.

only from the strictly theoretical but also from the experimental standpoint.

### (b) Mechanical Construction

Although the general theory shows that no side air pressure should be experienced in a well designed horn, it is found in practice that unless the horn walls are extremely rigid the walls will be set into vibration. The effect of this vibration causes a number of changes in the characteristic.

The setting up of vibration in the walls means that energy is being absorbed which should go into sound pressure, but because of the fact that these walls vibrate, this energy is expended in the form of heat. Then too, if such a wall vibrates at a certain frequency it will have an effect on the following tones in so far that this vibrating surface will then act as a source of energy and greatly modify the response at the succeeding frequencies, resulting in distortion.

As shown in Fig. 2, long air columns have been designed in which the entire air chamber is bounded by curved surfaces which have a maximum amount of rigidity and because of the fact that they are entirely enclosed in a metallic shell, vibration of the horn surface is eliminated. By means of a device, to be described in a subsequent article, it is possible to determine the effect of the equivalent horn opening or bell, which presents a uniform wave front resulting in a fairly uniform distributed sound field. The horn walls are made of a special ceramic material which is extremely dense and in itself acts as a very poor absorber of sound. This produces very high efficiency with regard to the device as a sound radiator. This type of construction incidentally permits of a maximum length of horn to be placed in a minimum space and when properly designed mathematically gives practically the same results as a straightaway horn.

### (c) Nature of the Walls of the Air Column

In order that the horn may act as a suitable sound radiator it is imperative that the walls of the structure be

extremely smooth and continuous. An ordinary automobile muffler is made with the chamber consisting of large sections followed by small sections; in other words, it acts as a sound absorber. In the case of a horn, the air column must be true to the design as laid out by the designer; that is, no obstructions or deviations from the perfectly smooth contour can be allowed if the frequency range is to be reproduced accurately. It is highly desirable in the case of a sec-



Fig. 4. Application of the unit to the air column. Note that the back of the speaker unit is open so that high frequencies are directly transmitted to the air.

tional long horn that no imperfections occur resulting from the joints of the pieces since that again acts as a deterrent to faithful response.

As shown in Fig. 2 this particular horn design is so constructed that the inside walls are perfectly smooth, and since the structure is in one piece, it is continuous from the throat to the bell. The result of this construction shows itself particularly in its ability to respond to the high frequencies, that is, frequencies in the neighborhood of 4000 and 5000 cycles. All the energy supplied by the unit is transmitted in its proper intensity through the horn.

An index of the performance of a long air column horn with respect to

its inside smoothness can easily be obtained by impressing such a high frequency on the unit and then noting whether or not the horn acts as a resonator or whether the sound energy is reduced over that obtainable in the unit when it is applied to the horn in question.

### (d) Mass Inertia of Loud Speaker

The primary object of the loudspeaker is to set the surrounding air into vibration. It must set up a certain radiation pressure. It requires no great stretch of imagination to see that if the sound radiating device is extremely light, that it will vibrate itself instead of vibrating the air. With this in mind experiments have been made to determine the necessary mass a loudspeaker must have for a given size, in order that it may transfer the maximum of available energy to the surrounding air.

Experiments prove conclusively that it is necessary to incorporate a definite amount of weight in a speaker and this was accomplished by making the walls of the speaker heavy and incorporating a definite weight in the horn. The required weight reaches an optimum point for every design and type of loudspeaker, beyond which no appreciable gain is found.

The 10 foot horn shown in Fig. 3 has an approximate weight of 185 lbs. The smaller models weigh proportionately less.

There is an added advantage in such a design, incorporating weight in so far that it prevents vibration of the speaker with a resulting lesser tendency to cause microphonic feedback or howling, often caused by vibration in the loudspeaker being transferred back to the detector tube in the radio set.

### The Unit

The floating type armature unit, originally invented by Frank L. Capps in 1890,\* has received much attention, particularly within recent years.

In this type of unit a small armature, surrounded by a coil through which the audio frequency current flows, is caused to move between the pole pieces attached to a permanent magnet. In its ideal condition the armature is intended to float between these pole pieces, being held in position generally by the rigidity of the diaphragm to which it is attached by means of a connecting pin.

This particular type of unit lends itself admirably well as a reproducing unit. There are many factors, however, which require careful study and design in order to make this unit perform satisfactorily throughout the frequency range. All the moving parts, that is, the diaphragm, connecting pin and the armature constitute a resonant system. It is apparent that this system will respond

\* U. S. Patent 44139.

easily to a number of definite frequencies. In early models, these resonant frequencies were placed up very high in the frequency range so as to coincide with the natural resonances of the horn to which it was coupled, resulting in great volume and efficiency, but such a speaker did not cover the musical frequency range adequately.

If the permanent magnet is made sufficiently strong the field on the armature, when it is moved from its central position, has a tendency to introduce flexibility into the system. And then, if a suitable diaphragm is used, the natural period of the entire system can be brought to a lower part of the frequency range. When a unit is connected to an oscillator, which has a uniform output at all audible frequencies, it is found that the armature vibrates and moves through considerable excursions at these resonant frequencies. In some cases it moves so far as to hit the pole pieces, causing a rattle at those particular tones. On the other hand, at the very high frequencies, the movement is very small. This means that in a design of such a unit, the air gap must be sufficiently large so as to allow the armature to move without hitting the pole pieces at the low frequencies, and at the same time it must be small enough to insure good efficiency when responding to the higher tones.

By the proper correlation of the air column and the unit, it is possible to so design the combination that the horn resonances of a medium length horn fall on either side of the unit resonance, resulting in a sufficient load on the unit, which prevents excessive movement of the armature and corresponding elimination of the rattle.

One of the general defects of the floating type unit is the fact that because of the indirect action on the diaphragm, the very high frequencies, that is, those between 4000 and 5000 cycles, are oftentimes not reproduced at all. The effect of the horn as outlined above, also has a tendency, unless properly constructed, to prevent transmission of these higher frequencies. The net overall result is that these higher frequencies, which are so essential to definition in music and clarity in speech, are found wanting. Careful design in the space between the diaphragm and the horn opening, as well as attention to the mounting of the armature and diaphragm, contribute much toward bringing out these frequencies.

It has been found by experiment that when the back of such a unit is covered, that the high frequencies are damped out very materially. A special design has been developed where the unit has a cap placed over the mechanism, which is open at the back, allowing the very high frequencies to be transmitted directly into the bell of the horn from the back of the diaphragm. This is clearly shown in the illustration of Fig. 4. The size of this

opening determines the necessary modifying effect of the frequencies in question.

### Electrical Characteristics

There are many other factors which contribute to the satisfactory performance of such a unit, aside from the mechanical details. One of these is the electrical winding of the unit which connects to the output tube of the radio set on which the loudspeaker is used. Because of the fact that space is at a premium, it has been found expedient to wind such coils with a very small wire, which is able to carry the current from the conventional radio tube, but in doing so there is always a tendency to saturate the armature by means of the direct current of the plate circuit.



Fig. 5. One of the drum shaped speakers completely mounted.

The output transformer and filter circuits, which have been devised by a number of manufacturers obviate this difficulty and tend to produce better tone quality because of the elimination of the diaphragm to merge with the speaker winding. The filter combination appears to be preferable from the standpoint of being able to pass the frequency band, perhaps better than the output transformer arrangement, although the latter entirely separates the speaker from the direct connection with the high voltage "B" supply in case power tubes are used.

### The Completed Speaker

From the above, it is apparent that a satisfactory reproducer can only be

obtained when the air column and the unit are correlated and so designed that the characteristics of one supplement the characteristics of the other. Fig. 4 shows the open structure of the air column and unit of one of the designs. The bell of the horn, as can be seen, opens up slightly different from the conventionally designed goose neck horn, but has been compensated to give a relatively flat wave front. The unit has been placed slightly to one side of the center of the opening so as to allow the high frequencies reproduced from the back of the diaphragm to merge with the sound energy coming from the bell of the horn.

With this particular design, it is a relatively simple matter to put the loudspeaker on an oscillator and determine the response at the various frequencies and then making such minor changes as may be necessary in order to produce as close to a uniform output at all frequencies as possible. Changes can be made in the air column or in the unit to aid in this respect.

In the case of the lower frequencies, the air column resonances bring up the efficiency to a very great extent, while on the higher frequencies the response from the back of the diaphragm and that coming from the horn bring up the response at that point to the proper intensity. The net overall result is that such a combination actually reproduces sounds from the very low frequencies up to 5000 cycles; that is, it practically covers the frequency range of the music transmitted by the majority of broadcasting stations. While it is true that the low and high frequencies are somewhat reduced in intensity, the reproduction is very satisfactory when compared against other types of loudspeakers.

Fig. 5 shows one of the completed speakers. There are two sizes. The smaller of these has an air column length of 54 inches, while the larger one has an effective length of 75 inches.

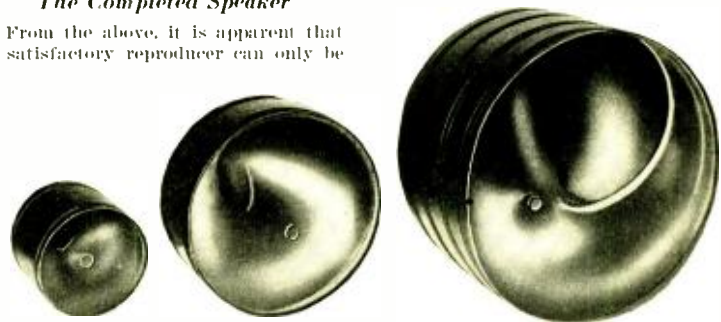
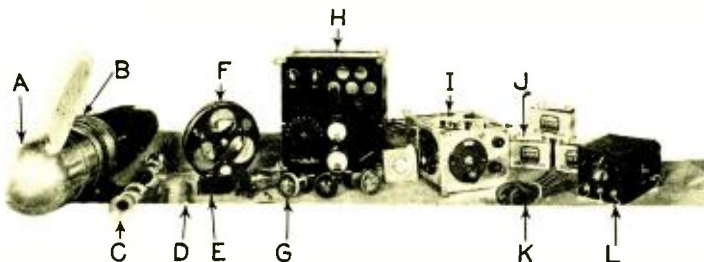

Fig. 2. Three types of coiled up exponential horns suitable for cabinet or external speaker application. These are made in one piece. The speaker units are attached to the small openings, as shown in Fig. 4.

# Aeroplane Radio Equipment

*The design and installation of radio equipment for long distance aeroplane flights*

By Bert E. Smith\*



Here is the complete layout of necessary material for a working installation. A, self-adjusting generator head; B, 900-cycle generator; C, fairlead; D, antenna fish; E, flame-proof key; F, antenna reel; G, UX-210 tubes; H, transmitter; I, receiver; J, "B" batteries; K, suspension cord; L, control box.

SINCE the recent Trans-Atlantic and Trans-Pacific flights have awakened a great deal of public interest in all things pertaining to aviation, radio has come in for its share, and a little exposition of some of the requirements for radio equipment on such flights may be of equal interest to the radio fraternity.

Where every ounce and fraction of an ounce is considered, it is, of course, practically impossible to use standard radio equipment, as all possible weight is required for the absolute essentials, such as gasoline and oil; so extreme lightness in the radio is of great importance. At the same time, unusual mechanical strength is necessary, in order that the steady and long continued vibration caused by the engine of the plane will not destroy either the set itself or any connections. Everything must be water-proofed with unusual thoroughness, for even in most cabin planes they are not absolutely weather tight, and the set must be so made that a more or less continuous contact with salt spray will not cause it to lose effectiveness. Space is at a premium, requiring the largest possible amount of power in the transmitter and sensitivity in the receiver in the very smallest amount of space. Last, but not least, the installation must be extremely simple to operate and thoroughly fool-proof in whatever adjustments are required, as most aviators are not skilled operators; and as the success of their flight and even their lives frequently depend upon the proper functioning of the radio equipment, every possible aid must be given them in making its operation of unusual simplicity.

### Most Desirable Wavelength Bands

The first consideration in the design is the determination of the wavelength

bands on which the equipment is to function, as many details in the installation would be changed with any variation in this factor. The greatest number of miles of communication per pound of installation are undoubtedly secured with short wave installations, but at least one tremendous drawback promptly presents itself—skip distance. This phenomena is familiar to all amateurs who have had the experience of having their signals heard with good audibility several thousand miles away, while anyone listening for them in the next county may remain totally unaware that they

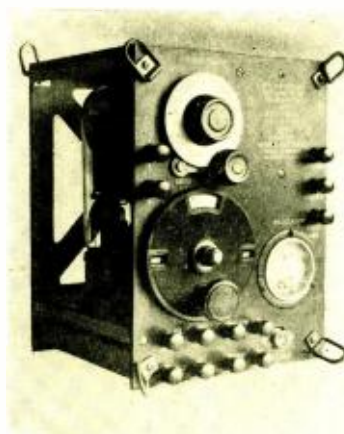

A 50-watt transmitter with crystal frequency control. This is the set Commander Byrd took over the North Pole.

were operating. For example, a signal transmitted on 20 meters from a point in the State of Connecticut will be absolutely inaudible just west of the Hudson River. It can be heard weakly in the extreme western part of

New York State, and will not be really of readable strength until the receiver is located in the vicinity of Chicago. In the Rocky Mountain territory, or on the Pacific Coast, it will be very strong, and will still be audible half way round the world.

The comparatively flimsy construction of airplanes is such that if they are forced, for any reason, to descend on the surface of the ocean it is unsafe to consider with any degree of assurance that they will remain afloat for more than an hour or two, and considering the average speed of steamers as about 15 miles per hour, we can readily see that their greatest hope of succor must come from steamers not more than a hundred, or if they are unusually fast, 200 to 300 miles away. Using 20 meters and radiating our signal from an airplane a mile or so up we should probably be inaudible where we were in need of most help, and putting a real loud S. O. S. signal into the home of an amateur 2000 miles away would not be of any great aid. Furthermore, very few ships are equipped to receive short wave signals, and therefore our chances of getting timely assistance would be even smaller, if short waves are to be relied upon.

If, on the other hand, we utilize 600 meters we cannot be heard several thousand miles away, but there is no skip distance, and our strong signals will be heard just where they will do the most good—within a radius of 300 miles. Furthermore, it is reasonable to assume that there will almost always be a ship within 300 miles and that its radio operator will be listening on the 600 meter band, so that the use of this wavelength makes it almost certain that a distress signal, if it becomes necessary to send one out, will be responded to without delay.

If the only concern were keeping in communication with shore stations in order to send back news of how the flight was progressing, weather reports, and similar messages, there would be much more advantage in the use of higher frequencies, but as the equipment is carried to a great extent as a safety factor, the commercial wave band becomes by far the best for us to use.

### Transmitter Circuit

Having determined the wavelength, the next problem is the selection of a circuit for the transmitter itself. It must be absolutely stable, and no other

\* Allen D. Cordwell Mfg. Corp.

adjustments should be necessary to set it in operation than the turning of the control switch to the "transmit" position. Thereafter it should be possible to shift wavelengths without any loss of efficiency by changing no more than one switch or dial. The maximum amount of signal power must be secured from the minimum amount of input power, and there must be absolute freedom from any possibility of breakdown or spark discharge from any of the parts, always taking care to keep the weight to a minimum and retain sufficient strength to assure that the vibration will not loosen the mechanical assembly or break any of the electrical connections.

### Design of Receiver

In the design of the receiver the problems are very similar. It must be simple of operation, having the minimum number of tuning controls. It must be sensitive so that the Pilot can receive messages from shore stations during the whole time of the flight. It must be completely shielded, both electrically and mechanically, in order that neither the vibration of the plane or the ignition system will interfere sufficiently to prevent the reception of signals, and above all it must be extremely economical of current consumption as batteries add weight with an awesome rapidity.

Much research along these lines has been undertaken by the various military designers, and by commercial interests working independently and their results may be divided into two major classes—the transmitter-receiver, in which the two functions are combined in a single set of tubes, and independent units where each piece of apparatus functions with one purpose only.

In the trans-coiver line there are a few drawbacks which have to a great extent prevented adoption where other than skilled operators are to work it. It is not as economical of power as the two unit system because in order to have sufficient power for the transmitter it is necessary to use tubes much larger than are required for receiving, and as the receiver is usually required to cover a fairly wide band the danger is great of transmitting on a wavelength where no one will be

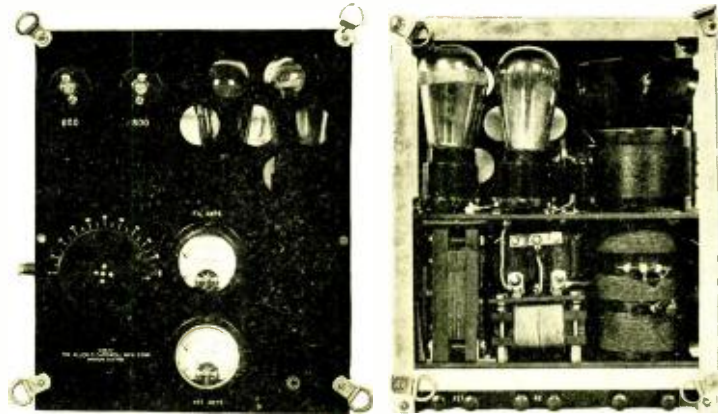

Front and rear views of a 30-watt aeroplane transmitter weighing about 14 pounds and with a transmitting range of from 100 to 1,000 miles. Two 210 tubes are used.

listening. The circuits also become rather complicated if the greatest efficiency is secured, and, therefore, this method is not very popular. When operated as a receiver it is, of course, dependent upon batteries as pure D.C. current is required, and to secure this from the same generator that is used to supply the power for transmitting would require a rather complicated, and of a certainty, a very heavy filter system. For this reason most of these sets are entirely battery operated, and the weight of the batteries is almost prohibitive.

A circuit has been developed for transmission alone which is extremely reliable, putting out a good strong signal with a minimum of power input and weight, and which can be adjusted as to wavelength, with only one dial, over a fairly wide band without any loss of efficiency at any point. It requires a minimum number of parts with consequent comparatively small weight, and furthermore can be entirely assembled in one unit without any external accessories other than the generator, key, and antenna. For a 30 watt outfit the transmitter need weigh less than 20 pounds and for a hundred watt outfit only a few pounds more.

### The Generator

The generator used for these installations is usually capable of develop-

ing about 200 watts and is mounted in the slipstream of the propeller on the outside of the fuselage, or on one of the wing struts, depending on the construction of the plane. It customarily furnishes alternating current varying from five hundred to a thousand cycles at a potential of 120 volts, which is led direct to the transmitter which contains two transformers, one stepping the generator current down to the proper voltage for the filaments of the tubes and the other raising it to the proper plate voltage.

The generator is equipped with a compensating head which is so built that a change in the load caused by pressing the key, which would normally slow down the generator, results in a change in the pitch of the driving propeller which automatically keeps the speed of the generator, and consequently its output, at the same figure regardless of variations in the load.

In addition to the standard 600 meter working wave the transmitters are usually arranged also to work on 800 meters, so that ships equipped with radio compasses can take bearings on the direction of the plane, and thus determine its approximate position. In order to assure the operator that he is on the proper wavelength we mount two small wave meters, each with a flashlight bulb indicator, on the panel, and when changing wavelengths the operator simply moves his dial until the bulb labeled "600" or "800" reaches its brightest illumination, at which point he knows he is transmitting exactly on the frequency desired.

### Layout of Apparatus

After carefully laying out the arrangement of parts in the transmitter unit the panel is planned to have all parts, to which nothing is attached, drilled away. A very light frame of aluminum channel is bolted to the panel and a shelf attached, on top of which sockets and transformers are mounted, and beneath which the in-

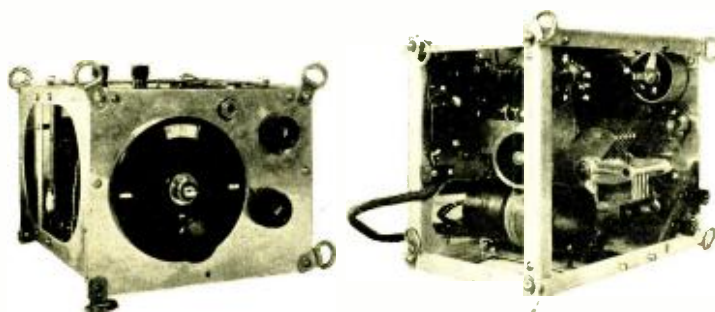

Interior and exterior views of a simple aeroplane receiver weighing less than 3 pounds. Note the lack of complicated controls.

ductance is suspended. The bases are removed from the sockets, and once again absolutely all unnecessary material is drilled away, leaving only a

Where more sensitivity is required or direction finding ability is wanted a four tube circuit is utilized, following very nearly the constants of the

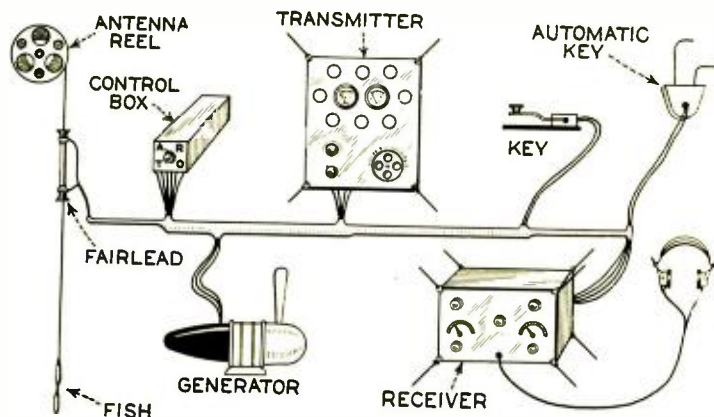

A pictorial diagram of a complete aeroplane installation employing the apparatus illustrated on page 970.

skeleton of supporting material. No cases are put on the transformers, but they are carefully impregnated to make them water-proof. Wire, with a heavy covering of live rubber, is utilized to make the connections and all joints after being carefully soldered are covered with live rubber tape. All the screws with which the mechanical assembly is made are locknitted and soldered down. Such adjustments as will have to be made in the test flight are supplied with spring clips, and after the final adjustment are also tied fast and soldered. Care is taken that all leads are supported at least every three inches along their length to prevent vibration working them loose.

The mechanical construction of the receiver is somewhat similar and rheostats and condenser shafts are set up especially tight to assure that they will remain in position in spite of an intensive shaking. As it is our intention to totally shield this, the panel is made of aluminum and the framework is joined to it. The socket panel is suspended on rubber. The audio transformers and other permanent parts are removed from their cases to eliminate all possible weight. Even the end plates on the condensers are changed from brass to aluminum in order to save the few ounces thus obtainable.

The "B" batteries are mounted in the bottom of the receiver and the whole thing is then tied up tightly in a very light aluminum cabinet.

For comparatively short distance operation, or when an unskilled operator is at hand, a three tube set is usually utilized, because of its simplicity. Such a one as shown in the photograph which has no controls other than one for wavelength and one for an oscillation control plus a filament rheostat. This receiver uses an ordinary single circuit regenerative hook-up, and weighs about two pounds and a half.

well known Roberts receiver. Provision is made for the use of a loop mounted in the fuselage of the plane or alternate operation from the antenna as usual. The receiver, including the "B" batteries, weighs, when completed, about thirteen and three quarter pounds.

#### Enclosed Key

A key of the usual type is used except that provision is made to enclose the contacts so that they will be absolutely flame-proof and no possibility will exist of igniting gasoline fumes at this point. If the installation is made on an open plane where the operator will probably be wearing heavy mittens, a large cup shaped button about three inches in diameter is substituted for the ordinary button. The same circumstances control the selection of headphones. If a cabin plane is used ordinary headphones with rubber caps are provided, but if the cockpit is open the receivers are sewed inside of the helmet.

It is, of course, frequently impractical for the operator to be on watch at the radio all the time, and a great deal of the safety factor gained by carrying radio equipment would be lost if the transmitter were not in operation the majority of the time. A small automatic device has been developed which, when attached in the proper way, will repeat the call letters of the plane continuously at either part or full power. This is driven by air pressure generated through a small tube projecting from the side of the fuselage. When a plane is equipped with one of these automatic keys, no attention need be paid to the radio equipment and still with the assurance that their signals are being heard regularly, and any unexplaining cessation will immediately send several vessels scurrying for the point where they were last heard, can be felt by the flyers.

#### The Control Switch

The control switch is, in its wiring, perhaps the most complicated piece of apparatus in the whole installation. Sufficient contacts are provided, once again in flame-proof enclosures, to make and break all the circuits necessary for changing from "off" through "receive" and "automatic" to "transmit," at each stage grounding all unnecessary circuits to prevent any possibility of their becoming charged through inductive or capacitive pick up. A four-throw, twelve pole switch is usually built as a base, and such alterations as are necessary can be made from this.

An adjustable fair-lead can be made from two brass bellmouths and a length of radiator hose. This is lashed in a position projecting through the under side of the fuselage, and the lead-in wire is soldered to both the inner and outer bellmouths, through which it secures contact with the antenna wire at least at one place all the time. Just above the inner bellmouth is mounted the antenna reel. Great care must be utilized in the selection of antenna wire as it must combine the virtues of extreme lightness and low wind resistance with unusual flexibility and strength. The fish (weights) which are attached to the free end of the antenna to hold it down are also carefully streamlined to reduce the impedance which they offer to the free passage of air. The antenna reel should contain at least three times as much wire as will be required at one time.

If for any reason the plane is forced close to the surface of the water or some other obstruction which may catch the antenna and break it off without the operator having a chance to reel it in, there will be no further possibility of communication, but if the reel contains enough wire a spare fish may be attached to the broken end, another length let out, and communication recommenced. During one of the Trans-Pacific flights the aviators were forced to descend very close to the surface of the water, and before doing so they sent out a distress message stating their position and saying that it would be the last call. Providentially they were able to re-ascend, but they had to approach so close to the water that their antenna was caught and broken off. Less than an hour later a ship was at the point from which the message was sent and, of course, found nothing. If additional antenna wire and spare fish had been provided they could have advised passing vessels of their ability to stay in the air and could have summoned need again should they have required it later in the flight.

#### Position of Apparatus

The position in which the apparatus is mounted usually varies with every installation and ship. In huge planes like those used by Byrd everything

can be mounted together, either in the chart room or the navigator's compartment, while in some of the smaller ones the apparatus may be scattered all over the ship. The control box, key and receiver must, of course, be convenient to the operator. The antenna reel must be in a readily accessible position, but it does not have to be varied regularly, so it can be put at some distance. The transmitter requires almost no adjustment, and if necessary can be stowed in the tail or one of the wing spaces.

Both transmitter and receiver must be protected thoroughly from vibration, and this is usually accomplished by suspending them from the framework of the fuselage by rubber cords pulled tight and lashed down. The wiring with which the apparatus is connected is heavily insulated with live rubber, and is carefully lashed to struts at frequent intervals to reduce the possibility of being shaken loose or broken accidentally.

At least one complete set of spare tubes should be provided for both transmitter and receiver, and brief but very complete instructions for operation should be in a prominent place to enable the pilot to send out a distress signal if anything should prevent the navigator from operating.

Instead of the regular equipment, many aviators wish the safety afforded by a continuous radio signal emanating from their plane without wanting the trouble of operating it, or caring about receiving messages. In such cases the generator, automatic key, and transmitter unit alone are installed with a single switch to set them in operation and they function continuously throughout the flight without any attention whatever.

#### Emergency Transmitter

Supplementary to, or sometimes in place of the full equipment described above, is a tiny emergency transmitter which operates independent of any outside agencies and which can be taken along in the event of a forced landing on the water in the collapsible life boat. This is an entirely self-contained spark transmitter with an output of about 50 watts. It is completely water-proofed and will operate with only an upper inch or so of the antenna insulator projecting from the surface of the water. A collapsible kite is provided with a lifting power of perhaps twelve pounds and a metal fish line is used for the kite string and antenna. The power is secured from a group of dry cells the size of flashlight batteries. The ground connec-

tion is, of course, a piece of wire thrown over the side of the boat. Such an outfit as this can be built to weigh, including antenna wire, kite, and all parts, less than eighteen pounds.

Successful operation; even when all possible precautions are taken, often presents nearly insuperable difficulties. Most aviators are not particularly good operators, and the combination of heavy Q R M with the static generated by the ignition system, is enough to daunt the best of "ops". Ears are deafened almost to the point of numbness by many hours of drumming by the huge engines and it seems more or less a miracle that a person who has spent a score of hours in the air can hear anything at all.

Transmission is a horse of another color. The high, clear tone of the eighteen hundred cycle note will penetrate a tremendous amount of interference, and the probability is that every operator who hears it will drop everything else and spend most of his time keeping tuned to the plane's wave. No particular skill is required to hammer out easily readable messages and the automatic key is definite assurance that some-one will be tuned to his wave when he goes on the air.

## Short Wave Transmitter Shows Characteristics of Light Propagation

*Five Meter, One Kilowatt Transmitter Is Elevated to Obtain Direct "Line of Vision."*

**I**N their pursuit of knowledge of the ways and habits of short waves, radio engineers of the *General Electric Company* have developed a 5 meter transmitter. Only preliminary investigation of the activity of this wavelength has been made, but already unusual phenomena have been observed and propagation tests will be conducted on a more elaborate scale.

The 5 meter wave has demonstrated some of the characteristics of light propagation. The signal follows a straight and unobstructed line. A receiver on a distant hill will pick up a strong signal but the same receiver, placed on the other side of the hill so that it is not within the "line of vision" from the transmitter, will get a barely audible signal. The hill seems to cast a "shadow" through which the signal penetrates with difficulty. Natural static was absent in the tests made, but man-made static, such as that from the ignition systems of automobiles, was very noticeable. Thus far the five meter signal transmitter has been tested only thirty miles away.

Engineers are now planning a test with receivers located on Lebanon Mountain, near Pittsfield, Mass., and about forty miles from Schenectady. The next test will be made between

Schenectady and New York. In this case the transmitter will be elevated about 300 feet and the receiver will be placed on top of the Woolworth Building in New York. A careful survey indicates that there is a clear "line of vision" between the proposed transmitter location and the Woolworth Building.

When dealing with short waves extremely high frequencies are involved. A five meter wave represents approximately 60,000,000 cycles per second. A four meter wave has a frequency of 75,000,000 cycles. In the space between four and five meters, 15,000 cycles, every radio station now in use, amateur, naval, broadcasting and commercial, might be operated without interference from overlapping signals.

#### Elevated Transmitter

Due to the peculiar nature of the five meter wave propagation the one kilowatt transmitter is constructed so that it can be elevated and swung from one of the 300 foot masts at the transmitter laboratory at South Schenectady. Two new-type, four-element air cooled tubes are used in the special oscillator circuit. The antenna which is about eight feet long, consists of a half wave radiator voltage fed, con-

nected directly to the oscillator. A meter in the middle of the antenna is used for measuring the antenna current and this is read by means of a surveyor's transit on the ground. Tuning of the transmitter at a distance of 300 feet is made possible by a special rope drive connected with a vernier control. Wires for supplying power and control are run to the transmitter from the ground.

The portable five meter receiver used in making observations of the special transmissions, is in all respects a miniature "ham" receiver, consisting of regenerative detector and one audio amplifier. The grid tuning coil consists of five turns of wire a half inch in diameter. The tickler coil is a quarter inch long and a quarter inch in diameter inside of the grid coil. Very small condensers located close together are used for tuning and regeneration control. Special low capacity tubes are used. Generally it is unnecessary to use any antenna, the phone cords picking up sufficient energy. An antenna may, however, be used.

Investigation of the propagation of five meter signals have only begun but it is possible that the engineer will in time find some application for the short wave.

# Report of the Fourth Annual Radio World's Fair

**T**HE Fourth Annual Radio World's Fair, held in Madison Square Garden, New York, during the week of September 19th to 24th, was probably the greatest radio exhibition ever witnessed. Being the official show of the Radio Manufacturers' Association, it held considerably more weight and was far more successful than it could have been otherwise.

Though in one sense, identical to the First RMA Convention and Trade Show held in Chicago during the month of June, it should be recorded that there was a larger exhibition of complete radio receivers and accessories as practically every radio manufacturer in the United States had his production program in full sway in time for the World's Fair while, on the other hand, many organizations were unable to exhibit their products as early as June.

According to reports, the attendance far exceeded that of last year. Undoubtedly this was partially due to the interest evidenced by the public in the new socket power receivers and socket power equipment which marks the major development of the year.

## Progress in Design

We are past the point of expecting revolutionary ideas or developments with the coming of each radio season. In the earlier stages of the progress of radio there were so many unexplored fields that it was not at all out of the ordinary to expect new and unique circuits and apparatus each month. However, radio has reached that stage of development where progress comes rather slowly and it is reasonable to expect that the near future will see nothing more than worthy improvements on present circuits and apparatus.

The outfits exhibited this year are veritable strong boxes built much in the manner of a battleship. Delicate instruments are cushioned, extremely well shielded, and supported by real steel frame works. With the exception of a very few cases compactness is the predominating feature.

The seven tube receiver of yesterday, which extended its bulk over an appalling amount of space, is now fitted into a small, well designed cabinet of about one-quarter the size. The layout of the apparatus, the wiring and the assembly of these receivers are made so that there is very little opportunity of any trouble developing and in the event of trouble the arrangement allows for convenient and rapid testing or servicing. In the case of receivers employing power amplifiers; as well as the power equipment

itself, wiring and insulation is in accordance with the Underwriters' regulations and provides the maximum safety to the user.

## Socket Power Operated Receivers

Battery operated receivers have not been forgotten in the mad rush for electrified equipment, yet practically every manufacturer of complete sets is offering this year receivers of both types. The electrified sets employ any number of different systems of complete battery elimination. Some of the receivers achieve this through the use of A-C tubes, lighted from filament transformers, while others employ the standard type storage battery tubes which are operated from "A" eliminators using a large rectifier tube, in which case the tubes in the receiver have their filaments connected in series, or obtain their filament current from an eliminator composed of a dry rectifier used in conjunction with a filter, or a similar means of rectification feeding a storage battery of low capacity or an electrolytic condenser.

Since engineers have been working on the problem of "A" elimination for a considerable time, it is safe to assume that most of the socket operated receivers are satisfactory from most standpoints irrespective of the type of "A" elimination employed. It seems that equal progress has been made in each of the various systems referred to.

## Circuits

As regards circuits, there is very little to be said. Practically all of the receivers are of the tuned radio frequency type using from one to four stages of shielded, tuned radio frequency amplification, and employ circuits which are, on the whole, very similar, with the possible exception of the stabilization systems employed. We venture to say that none of these systems are the product of inspiration but rather are the result of hard labor on the part of the engineers. Furthermore, it is probably equally as true that many of these systems could not be applied satisfactorily to any receiver deviating to any great extent from the original design. If ever radio engineers had to put in real hard work they certainly had to in designing the sets which are now on the market. More than ever, the responsibility is on the shoulders of the engineers.

For all of the complications in design, it is astounding how simple most of the sets are mechanically. If they are electrical masterpieces they are certainly mechanical masterpieces as well.

## The New Tubes

We find three or four new tubes in the rectifier class which are capable of passing from 300 to 400 milliamperes. These tubes are of the gaseous conduction type and were designed principally for supplying "A" current to receivers employing standard storage battery tubes with the filaments connected in series. Obviously there is sufficient current to supply both the "A" and "B" demands, as well as the "C" voltage.

Similar rectifier tubes of both the gaseous conduction and filament types are being marketed for use in connection with power amplifiers which use 171 tubes in a push-pull circuit or one or more 210 power tubes. These rectifier tubes are rated from 65 to 100 milliamperes.

There are two types of A-C tubes. One type employs a heater element aside from the usual filament, while the other type employs a heavy oxide coated low voltage filament. The heater element tubes have five prong bases with the exception of one make in which the heater element is connected directly to one of the filament legs inside of the tube, thus allowing for a four prong base. The filament of this particular tube operates at a comparatively high potential and low amperage, namely, 15 volts at .35 ampere.

No new power tubes were exhibited, though it is believed that there will be available in a very short time a 171-A tube and a 112-A tube, both of which will have characteristics similar to the present 171 and 112 but with  $\frac{1}{4}$  ampere filaments. The 112-A tube will be an R. F. and A. F. amplifier. It is very likely that a new power tube, similar to the 210, but with a much lower output resistance, will also be available in the near future.

A few manufacturers are supplying new tubes designed principally for radio frequency amplification and all of them seem to show a greater efficiency, when used for this purpose, than the standard 201-A type tube.

## Loud Speakers

Loud speakers seem to remain the bad boys of radio, though great improvement is evidenced in many of the new types exhibited. There are probably three times as many individual cone speakers as there are air column speakers, of exponential design or otherwise.

## New Products

Notable among the new products is an audio frequency transformer employing a cast core made of A-metal. Since A-metal is an alloy having an



extremely high resistance, the usual eddy current losses, which take place in the average transformer, are cut to a minimum, thus making a cast core permissible. An electrical remote control for radio receivers was also exhibited and is probably the first one of its type ever offered to the public. Through the use of a few relays and a reversible motor it is possible to tune a radio receiver, providing it has but one control, from a remote point. It might be interesting to note here that a great deal of work is being done on remote control systems and one company which does consulting work employs a novel system of remote control utilizing a step motor similar to the one developed by the Sperry Gyroscope Co. for the remote control of gun turrets on battleships. Another system of remote control, recently developed, is in the form of an external oscillator system and tuning is accomplished through the use of the beat principle. Another system employs a simple resistance bridge in connection with a reversible motor.

New in the parts field are many elaborate drum dials which heretofore could be enjoyed only by those people purchasing manufactured sets. The majority of these dials have a transparent scale behind which is mounted a small pilot light. The dials are provided with attractive protective plates which, when mounted on the front panel of the receiver, protect the dial from possible injury, and also serve as indicators.

#### Novel Demonstrations

A demonstration of a fire alarm device that literally "sees" and responds to the faintest trace of smoke was a part of the display exhibited by the Westinghouse Electric and Manufacturing Co. at the Radio World's Fair.

The agency that operates the alarm is a combination of a photo-electric cell and what is practically a standard vacuum tube—an achievement of Dr. V. K. Zworykin, physicist on the research staff of the Westinghouse Company. The tube is so responsive to light changes that smoke, as faint as a whiff from a cigarette, is utilized to turn on a red light.

The Knowles grid-glow relay, a power-controlling device so sensitive that the mere wave of a human hand will operate it, was also demonstrated.

Without even the incantation of mystic words, a practitioner of the modern black art of electrical wizardry passed his hand over a necromancer's crystal ball and presto! a large motor was set in motion and electric lights illuminated.

This feat is made possible by a tiny tube, closely resembling a vacuum tube in size and appearance, a product of the inventive genius of D. D. Knowles, a 28-year-old research engineer of the Westinghouse Company. For this invention Mr. Knowles recently was presented the John Scott Medal and a \$1,000 award in recognition of his valuable contribution to scientific knowledge.

The Knowles relay has an amplifying power of about one hundred million. The energy required to operate it is about one-billionth of a watt, or about one-fortieth of the amount of energy exerted by a fly in crawling vertically upwards one inch in one second. This infinitesimally small amount of energy is sufficient to start a current of as high as 25 milliamperes flowing through the tube. This latter current is sufficient to open or close a switch handling upwards of 25 amperes; and this, in turn, is ample for controlling almost any operation.

is mounted in a temperature controlled cabinet and suitable meters provided for holding driving voltages constant.

#### Determination of Frequency

Now that a primary standard source of alternating current has been provided some means of determining its absolute value is necessary. This is accomplished as follows:

The output of the fork driving amplifier is coupled to a power amplifier which drives a 1000 cycle synchronous motor which is geared to a counter. It is now possible to compare the revolutions of the synchronous motor and consequently the number of cycles of the fork to a known interval of time. This is best done by running the fork and motor over a period of 10 or 24 hours as measured by comparison with transmission of time signals from the U. S. Naval Observatory transmitted by the radio station at Arlington, Va. A receiver is set up and the readings of the counter made at the start and finish of the test period. The number of seconds in this period may be computed, then by dividing the number of revolutions of the motor by the number of seconds in the test period, the frequency of the fork is obtained.

By repeated measurements on successive days an accurate knowledge of the constancy from day to day is obtained.

For short periods of time the constancy of the fork has been determined by a chronograph and standard clock.

Having determined the absolute frequency of the 1000 cycle fork means must be provided for multiplying this frequency to the magnitude of frequencies used by Radio Stations. This is done by coupling the output of the fork to a 1000 cycle oscillator, using sufficient voltage to synchronize or pull into step this oscillator. This oscillator is designed to produce rich harmonics of the 1000 cycle fundamental. The tenth harmonic or 10,000 cycle voltage is selected and used to control a 10,000 cycle harmonic generator whose tenth harmonic or 100,000 cycle voltage is used to control a 100,000 cycle harmonic generator and so on, as far as the requirements demand.

Suitable means is also provided for the selection and comparison of any frequency in 1000 cycle steps throughout this range.

This apparatus consists of a frequency generator (sine wave) which is variable over the entire frequency range; a variable tuned circuit selector and an audio amplifier with visual or audible heat indicator.

The sine wave generator is provided with a straight line frequency vernier condenser which provides a means of obtaining frequency steps between the 1000 cycle steps readable to 20 cycles in the range of broadcasting frequencies. These intermediate frequencies may also be measured by the Campbell Audio Frequency Bridge or harmonics from a 100 cycle electrically driven fork both of which are provided as part of the standardizing equipment.

## Frequency Standardization Work

By W. A. Ford\*

**F**REQUENCY in this and most European countries is determined by the length of the sidereal day. A good clock as a standard of frequency would be excellent as to accuracy but there remains, however, the problem of comparing the frequency of, say, the swinging pendulum, with the much higher frequencies of the alternating currents as used for radio transmission.

An alternating current of one cycle per second could readily be obtained from the fork, but when this frequency is multiplied millions of times any irregularity in the period of successive cycles due to contacts, etc., would re-

sult in correspondingly larger errors in the final measurement.

The simplest way of reducing this error is to make the primary frequency as high as the demands of the work require, in this way reducing the amount of multiplication necessary.

In addition to this a driving force which is extremely uniform will also improve the accuracy.

For most of our work frequencies differing by 1000 cycles are sufficient for calibration purposes.

A 1000 cycle tuning fork was therefore chosen as the primary standard to be electrically driven by suitable vacuum tube amplifiers, thus providing a means of driving which is loosely coupled to the fork and will have the minimum effect upon it. This fork

\* General Engineering Laboratory, General Electric Company.

# Little Known Facts About the Well-known Gaseous Rectifier

*A romantic account of the progress made in the development of gaseous conduction tubes*

By Austin C. Lescarbours\*



A bank of test racks where the gaseous conduction rectifier tubes are put through their paces. A few of the racks are used principally for conducting life tests.

**S**IMPLICITY is often deceiving. Thus the well-known gaseous rectifier, with its lifeless operation—free from bright filament, glow or noise, and with only a slight warmth of the glass bulb to indicate operation—represents one of the most brilliant advances in the radio art, and a triumph of intensive research. Indeed, the development and refinement of this device has involved a review of many rare gases, a deep study of atomic structure, and a long process of reasoning out the aerobatics of electrons. The highly intricate action taking place in the miniature universe of the gas contained in the gaseous rectifier is, therefore, not at all in keeping with the utter simplicity of the mechanism and electrical features of the device; yet we must master the first before we can enjoy the second.

Not so long ago the writer had the rare pleasure of spending an afternoon with Charles Grover Smith, or simply C. G. as he is called, who was

\* In Consultation, Raytheon Manufacturing Co.

that day at work in the laboratory—or rather one of the several laboratories dedicated to gaseous rectifiers. On an immense life rack were numerous tubes of all possible shapes and sizes and types, some glowing with purple and pink and yellow luminescence, and others seemingly dead except for the heat which they threw off. By means of an elaborate spectroscopic, or device which permits of chemical analysis by means of the spectrum or color bands produced by various elements, C. G. was busily engaged in checking up the exact nature of the gas content of each tube in turn. In a general way we were informed that a pinkish glow indicated neon, while a lavender glow indicates helium, these two gases being most common in gaseous rectifiers. Furthermore, gaseous rectifiers wear out through the clean-up or exhaustion of the gas quite as much as through the deterioration of the anodes, and it is only through years of experience backed up by unlimited research that these problems have been mastered in the present-day tubes.

## *Evolved from Original "S" Tube*

It seems that the gaseous rectifier had its origin in the "S" tube of "ham" or radio amateur fame. In cooperation with Professor Vannevar Bush, who has charge of graduate research in the electrical engineering department of M. I. T., C. G. Smith evolved the first practical gas conductor tube, which was called the "S" tube.

Of course the possibilities of gaseous conduction and rectification had long been realized. Much had been said and even more had been written on the subject. Even the idea of the short-path insulation, which makes the practical gaseous tube a reality, was long known to technicians, having been discovered by a German scientist. It remained for C. G. and his associates, however, to take the short-path principle, together with a better selection of gas, and evolve a practical gaseous rectifier, which became the "S" tube, intended for rectifying high-voltage current for radio transmission purposes.

## *The Short-Path Principle*

The short-path principle is one of those scientific truths that are stranger than fiction. Briefly, in a gaseous conducting medium, if we have oppositely charged metallic bodies of sufficiently high potential difference, the gas between will break down or ionize, and conduction will take place from one to the other. However, move these same conductors very close to each other, and the gas between is no longer ionized, which is apparent from the fact that there is no longer a glow present in the tube. Current ceases to flow from one to the other. An excellent insulator is now presented by the intervening gas. Why?

The reason is steeped in academic science, which is usually far beyond the realm of the layman. Furthermore, no one has ever seen atoms or electrons, hence cold logic steps in to explain things which man may never see for himself. However, if we may be permitted to make a free translation of C. G.'s explanation into lay language, the story runs about like this:

## *The Whys and Wherefores*

The facing charges of electricity are bound to result in action. Some loose electron in the gap between the charged conductors is coaxed toward

one or the other, and rapidly accelerates its rate of travel until its speed is sufficient to smash those atoms obstructing its path. The collisions result in ionization, or the breaking down of the gas which then becomes a fair conductor of electricity, or, to put it another way, there is now a wholesale movement of electrons. It is evident, then, that the electron needs a good running start, so to speak, in order to smash things up in general. Failing in a good running start, the electron does no smashing, ionization cannot take place, and there is no electrical conduction, with the gas, under such circumstances, a good insulator. Some gases require a longer path for ionization than others, which is another important consideration. Helium is especially ideal in this respect, having an exceptionally long free path.

The short-path principle, then, is merely to prevent electrons from getting a good running start. This principle can then be applied in insulating the small anodes most effectively, since all but the tips can be insulated by the simple expedient of a narrow film of gas. Thus the anodes are kept reasonably cool. There is no glass or other surrounding insulating material to deteriorate under the terrific electronic bombardment. The principle of short-path insulation, first applied in the "S" tube, made the gaseous rectifier feasible. Helium was selected as the gaseous conductor for the reason that the helium atom must be subjected to a more violent impact be-

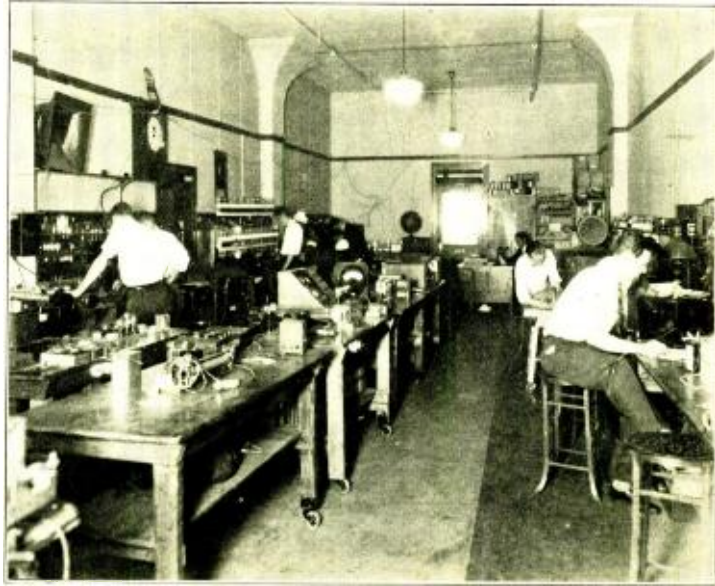

A section of the Customers' Service Laboratory where research work is done on "A" and "B" units designed for gaseous conduction, full wave rectifiers.

fore it releases its electrons and therefore causes ionization, than in the case of any other known gas.

#### Construction of Tubes

Now if we open up one of the tubes, we find the short-path insulation employed for the anodes or metal rods coming up through the glass stem and projecting slightly into the space

formed by the arched cap or cathode. The bottom disk of the cathode comes very close around the two metal rods or anodes, and the short path insulation thus provided means the best insulation possible in a gaseous atmosphere of this kind. It is infinitely better than insulating sleeving, such as that employed farther down on the anode rods or outside the electrical field. Any insulating material, subjected to the electrical and heat stresses of glowing electrodes, would soon break down. With the short-path construction, however, the electrodes or anodes are free at their ends, surrounded by the gaseous conductor which becomes an insulator only between the rods and the surrounding metal plate where the former come through and protrude into the cathode cap space. In action, the entire space within the cathode cap is glowing with a bright lavender luminescence, but this is not seen in the usual tube because of the encasing cathode which serves a very definite purpose in assuring maximum life for the gaseous rectifier.

Simple, isn't it? Yet years upon years of effort went into the harnessing of these simple principles. All manner of gases were tried, although C. G., from the beginning, when he was engaged in research work at Harvard, had a fond preference for helium, knowing of its exceptionally long free path or greater applicability to the short-path insulating technique.

Today all this work is represented in the practical gaseous rectifier tube found in hundreds of thousands of homes, operating radio receivers in place of "B" batteries, and, in some cases, even replacing the "A" and "C" batteries in addition.

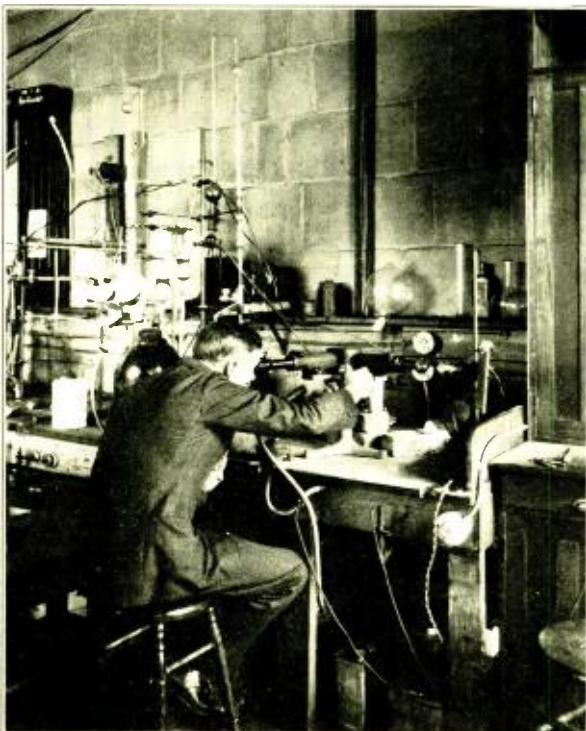

Determining the chemical analysis of the gas in tubes by means of a laboratory spectroscope.

# The "Super-Hilodyne" Circuit

*A new balanced push-pull tuning system and untuned radio frequency amplifier*

*By Fred A. Jewell\**

FROM the beginning of the era of broadcasting and the reception of radio programs, the desire of every radio engineer has been to develop an ideal radio receiving circuit. True, much has been done since the days of the old regenerative single-circuit tuner, but up to the present time we have been far from the much coveted goal. After many years of constant research work, the author respectfully submits the "Super-Hilodyne" circuit to the radio world as the nearest approach to such an ideal circuit.

Just what would constitute the ideal radio receiver? This is a logical question which should be answered before a description of a circuit is given that will meet these requirements. First of all, perfect quality of reproduction; second, absolute selectivity; third, ample volume; fourth, unlimited range; fifth, stability in operation; sixth, simplicity in tuning; and seventh, elimination of undesirable interference.

Now in a theoretical resume of the Super-Hilodyne circuit, it will be shown the why and how this circuit will come the nearest to meeting the requirements of this ideal receiver.

Fig 1 is a schematic diagram of the tuner. Only two variable condensers are required to get perfect selectivity without any danger of cutting off any of the side bands. This circuit functions as a wave trap that completely cancels all signals except the frequency that is desired to be received. Due to this fact it is able to work far below the present static level as only

the static on the particular frequency that is to be received is passed, the balance being cancelled out. Incidentally, it is also able to work under the towers of the most powerful broadcasting station without the slightest interference and in the most congested districts as well as in locations where interference from local disturbances are most pronounced.

There is no claim that this circuit completely eliminates static and all other interference, but it does confine such interference to the particular frequency of the wave that is to be received by eliminating or cancelling out the balance. Therefore, this circuit will work far below the so-called static level of the conventional radio receiving circuit of today.

### Principle of Operation

We will see just how this is accomplished by following the course of a signal picked up in the antenna and ground circuit. This signal is transferred from inductance, L-1, which is the primary of the tuned radio frequency transformer L-2; C-1 being the variable capacity, that is tuned to the frequency that is to be received. This signal charges the grids of VT-1 and VT-2 negative and positive alternately but as the grids of these two tubes are connected in opposing potential relation to each other (push-pull fashion) it is observed that when the grid of VT-1 is negative, thereby causing a drop in the flow of plate current of this tube, the grid of VT-2 is positive, causing an increase in the flow of the plate current of this tube in

the same proportion as the drop in current flow of VT-1. Therefore, if coil, L-3, is completely short-circuited by the resistance, R-2, the flow of current at point X would always be the same, as the plates of VT-1 and VT-2 are connected in parallel; just opposite to the input circuit. Consequently, no matter how powerful the signal is received in L-2, there would not be any variation of current at point X. This circuit is then a perfect neutralized circuit, balancing out signals of all frequencies.

Now we have a circuit that cancels out all signals and if in some way we could not pass the frequency of the signal that is desired to be heard, this circuit would be absolutely worthless, as it would not receive anything.

However, there is a variation of current flow between the plates of the tubes and point X. By connecting L-3 in series with the plate of VT-1, we have a variable signal flowing in this coil, if the resistance, R-2, is allowed to be opened.

L-4 is the inductance of the by-pass circuit that is tuned to the frequency that is desired to be by-passed by the variable condenser, C-2, and is in inductive relation with coil, L-3. The signal of the particular frequency to which L-4 is tuned is picked up by coil, L-5, and is conductively coupled to the grids of VT-1 and VT-2 through the coil, L-2. The potential of the current flowing in L-5 charges the grids of the two tubes at like potentials, as they are in parallel relative to L-5, which is just the opposite to the current that is picked up from the antenna and ground circuit. There-

\* Chief Engineer, Algonquin Electric Co.

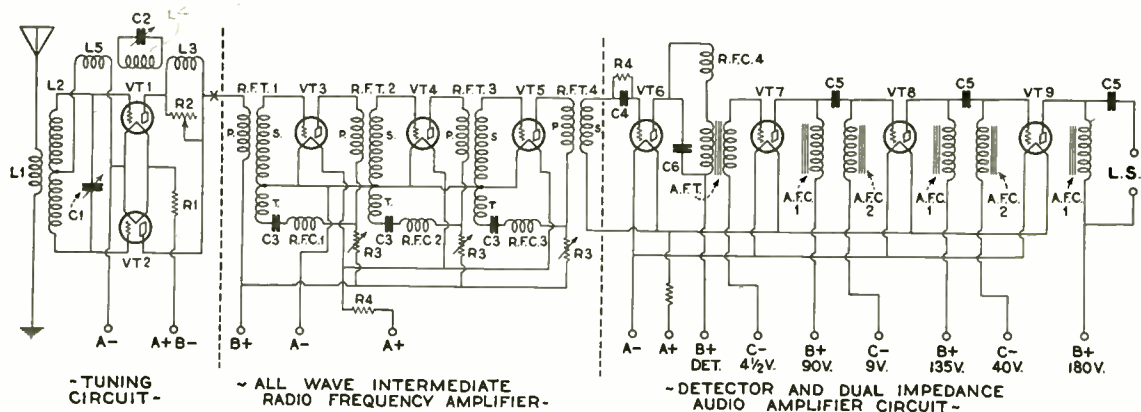

Fig. 1. The fundamental "Super-Hilodyne" principle is represented by the first portion of the diagram, divided off from the rest by a dotted line. This scheme can be adapted to various r. f. circuits but is particularly adaptable to the "Hilograd" system, the second part of the circuit shown above. This r.f. amplifier is of the untuned type but has a high degree of efficiency due to the fact that regeneration, which is automatically controlled, is present at all frequencies. As will be observed, the A. F. amplifier is of the double impedance type.

fore, the grid input of VT-1 is reinforced by the current transferred from L-3 to L-5 through L-4, while the grid input of VT-2 is balanced out, causing no flow of current from the plate to point X at whatever frequency L-4 is tuned to, while a greater amount of current at this frequency flows to the plate circuit of VT-1. Therefore, an amplified reinforced signal at whatever frequency is by-passed by L-4 flows in the primary of the radio frequency transformer, while all other signals are cancelled out.

### The Intermediate Amplifier

The tuning circuit of the Super-Hilodyne takes care of the second, fifth, sixth and seventh requirements of the ideal radio receiver,—let us pass to the fourth requirement which is range and which is taken care of in the intermediate radio frequency amplifier.

The object of this amplifier is to amplify any signal that is picked up by the antenna regardless of how weak it is. Just so it is strong enough to actuate the grids of the first input tubes to a point where it will be rectified by the detector into an audio frequency current sufficiently strong so that the audio amplifier will be allowed to work at maximum efficiency.

The method of the intermediate radio frequency amplifier is the untuned Hilograd system of which there is three stages. The advantage of this system of amplification is that there is no danger of cutting off any of the side bands, thereby causing distortion, as it is untuned and each tube is allowed to perform at maximum efficiency over the entire band of broadcast frequencies. The amplification factor of these three stages is sufficiently high to give almost unlimited range and as stated above, any signal that is strong enough to actuate the grids of the first tubes will come through in ample volume. Obviously, any signal that is not received with sufficient intensity to actuate these grids will not be amplified to a point that it would be audible, regardless of the number of stages of amplification that is used as it is impossible to amplify a signal which you do not get.

### Explanation of Hilograd System

Referring to the schematic diagram RFT-1-2-3 and 4 are untuned radio frequency transformers, giving a high degree of amplification between 220 and 300 meters. Inasmuch as these transformers are of the same resonance frequencies, if the resistance R-3 was not in series with primary of same, this system would oscillate and therefore be useless as an amplifier. However, the resistance R-3 is increased to a point just below oscillation so the amplifier will work at maximum efficiency between 220 and 300 meters. As the amplification factor begins to drop off above 300 meters,

part of the current of the plate circuit is fed back to the grid circuit through the radio frequency chokes, RFC-1-2 and 3. This current is forced through these chokes and condenser C-3 to coil T, and to the filament or ground as these chokes have a lower resistance than R-3 at the lower frequencies or higher wave lengths.

As it is a well known fact that the resistance or reactance of a choke drops as the frequency is lowered, more current will be fed back to the grid circuit in proportion to the drop in frequency. Now as coil T is coupled to the secondary of the radio-frequency transformers, we have an automatic electrical form of regeneration that compensates for the drop in amplification on the higher wave lengths, or the lower frequencies, which keeps the amplification factor at the highest point of efficiency over the entire wave band.

Let us consider a signal of 250 meters flowing in the primary of RFT. This signal is induced into the secondary and is then amplified and passed on to the next radio frequency transformer and as these transformers are in resonance, the tube would oscillate, but for resistance R-3 which is increased to a point below oscillation at this frequency. Practically no current is forced back to the grid circuit as the resistance of the RFC chokes is too high to allow a frequency of over a million cycles to pass through.

After the resistance R-3 is adjusted so that the amplifier is stable and is operating at peak efficiency no further adjustment is required.

As the signal of a lower frequency, say 350 meters, is passed in the same way as the 250 meter signal was, we find that some current is forced back through to the grid by R-3 through the RFC choke as this choke has a low resistance at this low frequency and as we go to a still lower frequency, say 500 meters, we find that still more current is forced back to the grid circuit as the resistance of the choke has dropped still lower, giving us an automatic form of regeneration at all frequencies.

Now as the interstage coupling is very close, we have a maximum transfer of energy from tube to tube plus the amplification factor of the tubes as well as automatic regeneration. These three stages can be depended upon to deliver a powerful signal to the detector regardless of how weak it may be received.

### The Audio Amplifier

As the detector circuit is conventional, we will pass on to the audio amplifier which is a Dual Impedance System. This will take care of the first and third requirements of the ideal radio receiving circuit which is quality of reproduction and ample volume. This type of amplifier has several notable features. One of these

is by the combination of the transformer in the first stage where the signal is the weakest. It will not overload the transformer and with the dual impedance stages following, it will furnish a greater amount of amplification than either of the usual two stages of transformer coupling or the usual three stages of resistance or impedance.

The low frequencies are amplified just as much as the high frequencies for two reasons: first, by the use of large coupling condensers and large impedances, giving the lower frequencies substantially the same amplification as the high frequencies; secondly, as the inductance of the plates and grids are staggered, one being very high and the other much lower, there is no danger of audio oscillations or "motor-boating" even when used with a power socket supply.

It will be noticed from the schematic diagram that there is a radio frequency choke RFC-4 and a by-pass condenser C-16 in the plate circuit of the detector tube. These are incorporated in the circuit in order to keep any radio frequency current from entering the primary of the audio frequency transformer AFT. In the output circuit of the last tube of the amplifier, there is a similar system. This one is employed to keep the high voltage necessary for the proper functioning of the power tube out of the windings of the loud speaker.

The volume control is in the tuning circuit, which is the variable resistance R-2 and serves to modulate the signal to the desired volume as well as to control the balancing of the tuner. This prevents any overloading of the radio frequency amplifier and detector as well as the audio amplifier.

In closing, it might be well to say that the Super-Hilodyne is very simple in construction, requiring no shielding or defecancy in the placing and arranging parts or in the balancing of the circuits.

### Errata Notice

Referring to the article "A New A-C Tube" appearing in the September issue of RADIO ENGINEERING, in rewiring a D-C receiver for use of the A-C tubes described, the following points should be born in mind:

All grid returns having common bias should be grounded. The detector grid return should also be grounded when employing the usual grid current-grid condenser, rectification arrangement. Minus  $1\frac{1}{2}$  volts should be grounded while plus  $1\frac{1}{2}$  volts is connected to the cathode post on some tube (which is the plus post on D-C tubes) along with the B minus, detector negative C, and power amplifier positive C.

The preferred volume control takes the form of a zero to 200,000 ohm resistor connected across the r. f. secondary preceding the detector tube.

# The Photo-Electric Cell

*Uses to which a Photo-Electric Cell can be put*

By Dr. Robert C. Burt, E.E.

## PART II

**I**N our previous article we took up the theory of the Photo-Electric Cell, and in this one we will consider a few of its over-all characteristics as a special type of vacuum tube.

In Figs. 1 and 2 are seen characteristic curves of the photo cells.

In the use of photo-electric cells we have four variables; they are light energy, wave length or color, applied voltage, and current. Fig. 1 shows the relation between current and wave-length. Curve 1 is for a light atomic weight alkali like sodium or lithium, and II for a heavier atomic weight material such as potassium and rubidium.  $\lambda_0$  is in each the long wave length limit and  $\lambda_m$  is the wave-length at which maximum current is delivered. This curve is the result of a number of phenomena, including the velocities considered last time, and also absorption coefficients for the different wave lengths. Value of  $\lambda_m$  given by experiment on certain cells is as follows:

Lithium	4050A°
Sodium	4190A°
Potassium	4400A°
Rubidium	4730A°
Caesium	5390A°

For convenience of engineers, let it here be explained that one inch equals 2.54 centimeters; one centimeter equal 10 millimeters, equals 10,000 $\mu$ , equals 10<sup>7</sup> $\mu\mu$ , equals 10<sup>8</sup> A° and A° is the symbol for Angstrom. These are all used as units of wave-length, but there should be no confusion because they are all multiples of ten of the standard centimeter length.

Fig. 2 is the voltage current relation. A is a vacuum type cell at high illumination and B is a vacuum type cell at about one-third this illumination. These curves are similar in shape, only differing in height over a range of at least 10,000 fold in light intensity. Curves C and D are similar curves for a gas cell; at higher voltages the cell is unstable and likely to arc.

### Uses for Photo-electric Cell

Having such a photo-electric cell, what can it be used for?

At the present time it seems as if the photo-electric cell might prove useful for the same things that the human eyes are used, and many things that the eye cannot be used for. Many things have been suggested, but the surface has hardly been scratched. Photo-cells are suggested for—

1. Counting and timing of passing objects
2. Transmission of speech and signals over a beam of light

3. Sunshine detector
4. Sign control and illumination control
5. Burglar alarm
6. Storm detector
7. Measuring photographic plates and spectrograms
8. Transmission of pictures by wire and wireless picture movies
9. Reading common print to the blind



A high vacuum photo-electric cell without appreciable fatigue.

10. Photometry
11. Pyrometry
12. Registering smoke
13. Measuring gas chart
14. Control of lighthouses and light buoys
15. Ultra violet light houses
16. Ultra violet burglar alarms
17. Sorting objects by color
18. Talking motion pictures and phonographs.

We will now proceed to take up a few of these in brief detail:

### Counting and Timing of Passing Objects

Such for instance as the counting of automobiles passing through a tunnel or by a given intersection; or the counting of a certain type of carton passing down an endless belt in a manufacturer's packing room, or the timing of races from the fastest to the slowest, or the measurement of the muzzle velocity of a projectile; these are all done in a similar way. A beam of light is thrown into the photo-electric cell causing the current to flow. When an object passes, the light is interrupted and the interruption of the current allows the relay to close which registers the time of the count.

### Transmission of Speech and Signals Over a Beam of Light

If a shutter is placed in a searchlight beam, and the search light is aimed at a photo-electric cell, the shutter may be operated in the form of telegraphic code, and the photo-electric cell will respond to the light impulses giving electric impulses which can be recorded. The light from the searchlight beam can be made invisible by passing it through an ultra violet filter. Speech may be transmitted in this way by causing the light from the searchlight beam to vary in accordance with the voice currents in a telephone line. The resultant variations picked up by the photo-electric cell are translated into audio currents.

### Sunshine Detector

This is probably the simplest use of a photo-electric cell. Nothing is required but a sensitive meter and batteries. When the sun shines brightly on a photo-cell, the battery will be permitted to send a large current through the meter. When darkness comes the current through the meter will cease. This can be easily applied to recording instruments, or it may operate a relay controlling an electric sign, or an illumination system, so that should the amount of sunshine drop below a certain value, the signs or illumination would automatically turn on.

### Storm Detectors

These can be made by a simple extension of this idea. The photo-electric cell may be placed at the end of a long, black tube and aimed at that part of the sky which grows black when a storm is brewing. A relay and bell then given warning of an approaching storm, or in localities where storms come from many directions, the black tube and photo-cell

could be mounted on a weather vane so that it would always point to windward. A similar application is the burglar alarm in which an automobile spot light is placed in one part of the room and its beam reflected back and forth by mirrors until it has traveled in the form of a lattice across doorways and windows, it is finally reflected by the last mirror into a box containing a photo-electric cell. Light shining upon this photo-electric cell holds a balanced relay from turning in the alarm; should the light become stronger or weaker the alarm will respond. If a burglar enters the building he must pass through at least one beam of light and that is sufficient to turn in the alarm. If he tries to fool the alarm by putting his flash light in, it will set off the alarm. Smoke from a smoldering fire will likewise set it off. This device may also be made invisible by the use of ultra violet filters.

### Measuring Photographic Plates and Spectrograms

This requires only a sensitive recording instrument, a source of light and a slit. Such devices are extremely useful because the line characteristics in the spectrogram is translated into an enlarged curve of density on which the maxima and minima are easily located.

### Transmission of Pictures by Wire and Wireless

In this process the photograph is curled in the form of a cylinder being caused to rotate like the cylinder in a cylinder phonograph. A stationary beam of light travels over this film in the form of a spiral the same as the needle travels over the cylinder record of a dictaphone. The light passing through the photograph varies in intensity as the light and darkness

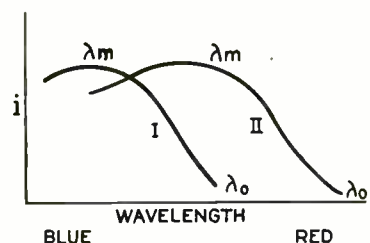

Fig. 1. Characteristic curves of a photo-electric cell, showing the relation between current and wavelength.

of the photograph itself. The photo-electric cell responds to this light and darkness with varying current which variation is transmitted by wire or wireless to the receiving station where it causes a photographic negative to be exposed as it travels in a synchronous path before the varying light.

Television is an extension of this process, and involves primarily the transmission of sixteen such pictures per second. Many different schemes are used but they are all basically quite similar. To consider this briefly, let

us make a few assumptions, and see where they lead us to.

We will assume the following: Each picture to be transmitted is  $\frac{3}{4}$  inch by one inch, sixteen of these are to be transmitted in one second, and a revolution of 1/100 of an inch is desirable. This means that our individual pictures can be divided into squares 1/100th of an inch on each side. In each picture there will be then 75 times 100 or 7500 of such squares; sixteen of these a second will mean 120,000 per second. Now it is quite obvious that to transmit as many as 120,000 variations in one second will require very quickly responding electric circuits, detectors, amplifiers and lights, if it is all to be done by one photo-electric cell and one transmission circuit. Another scheme would be to have one hundred photo-electric cells each transmit one of the 100 squares across the film; then each one would have to transmit only 1200 impulses in each second, but the cost of one hundred such transmitters would be out of the question. The final solution will probably be a compromise between these two. There is no difficulty with a photo-electric cell because it will probably respond to frequencies of one to sixteen million, it being a pure electron discharge in a high vacuum tube of extremely low capacity. From this we see that for quickness of response a photo-electric cell is faster than the human eye by a million times. Outside of circuit difficulties, the greatest obstacles to television is to get sufficient illumination and make it respond to the frequency. The gas discharge lamps will respond to high frequency but their illumination is very low. An incandescent filament is, of course, out of the question, as it scarcely shows a flicker in 120 vibrations per second. The arc lamp will only respond to slightly higher frequency. A possible solution is found in the polarized light magneto optic shutter. If space permits I will try to mention more of this at some other time, giving some numerical data.

### Reading Common Print to the Blind

If light from a written page is focused by a lens upon a row of photo-cells, and each photo-cell is connected to an audio-frequency oscillating circuit of a different pitch, then this arrangement may be drawn across a printed line of common type, and as each letter is passed over different chords will be sounded in different orders for each letter passed over. The result is that a blind person can have a book read to him by such a device.

### Photometry

Photo-electric cells are used for measuring the illumination in the calibration of incandescent lamps, in measuring the illumination in rooms, and in picture studios. The equipment is similar to that suggested for sunlight recording.

Pyrometry is the measurement of temperature by visible radiation and is accomplished by a similar method as photometry.

### Registering Smoke Passing Up a Chimney

This is accomplished by placing a constant source of light on one side of the chimney and recording the amount of that light which arrives at the photo-electric cell on the opposite side.

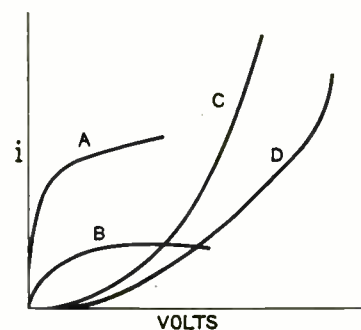

Fig. 2. Characteristic curves showing the voltage current relations.

Control of lighthouses and light buoys is simply an adaptation of the system used in controlling signs and illumination. In connection with lighthouses, since the photo-electric cell is sensitive to light which is outside of the visible range, it is possible that uses may develop in which lighthouses send out invisible light which will penetrate fog better than visible light will, and this will be detected by photo-electric cells instead of by eye.

### Sorting Objects by Color

In sorting of yarns, cigars and other things by color, a group of photo-electric cells are used, each with its appropriate color filter. The response of these photo-cells control the sorting mechanism.

### Talking Motion Pictures and Photo-electric Phonographs

The record of speech may be recorded on the same film as that on which the motion picture is taken by using a microphone, amplifier and gas discharge tube to expose the photographic film. When this is developed and printed the result is automatic synchronizing of the voice and picture record. While the picture is being projected light passing through the voice record into a photo-electric cell translates it into electric current which amplified will operate a loud speaker. The photo-electric phonograph is simply talking film without the movie. It is obvious that there can be no needle scratch when the needle is a beam of light.

In my next article I will try to give some of the common circuits and details for using the photo-electric cell.

# The Cathode Ray Oscillograph Tube

*This tube is a whole laboratory in itself and can be used for conducting all manner of tests*

*By John F. Rider, Associate Editor*

**T**HERE is available for the scientific service man, a piece of laboratory equipment which in its scope of operation and field of utility, is without a peer. This unit is the cathode ray oscillograph tube, a by-product of the Bell Telephone Laboratories of the Western Electric Co.

### Description of Tube

Before we enter into the field of operation of this marvelous laboratory unit, let us devote a few minutes to

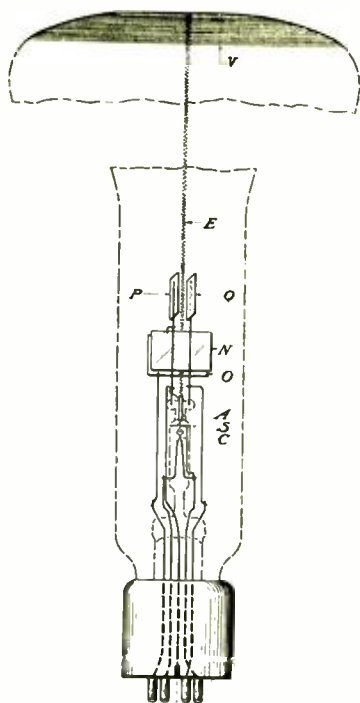

Fig. 1. A phantographic view of the Cathode Ray Oscillograph Tube. V is the viewing screen; P-Q and N-O the deflecting plates; E, the cathode ray; A, the anode; S, the screen and C, the cathode.

the tube itself, to its constructional details. The cathode ray oscillograph tube, as shown in Fig. 1 is a pear shaped bulb, with the active metal elements contained in the narrow neck of the bulb and the fluorescent screen is located on the wide part of the bulb. This fluorescent screen is spread over the inner surface of the bulb. The active elements within the tube consist of a filament, the source of the electronic beam, a metal shield, a platinum sleeve, two sets of non magnetic deflecting plates, a small

amount of argon gas and the fluorescent screen. The cathode or filament and the shield are located in a small bottle shaped glass tube, fitted in the neck of which is the platinum tube, functioning as the anode, and through which the electronic stream is projected so as to pass between the deflecting plates.

After leaving the cathode or filament and passing through the tubular anode, the electronic stream passes between two pairs of non magnetic deflector plates. These plates are rigidly fixed to the inner glass tube and are arranged in parallel pairs, the two pairs being at right angles to each other. One plate of each pair is connected to the anode, and is therefore maintained at a potential governed by the potential of the anode. The other plate of each pair is arranged for connection to one of the potentials to be observed.

The function of the argon gas within the tube is to focus the electronic stream. Without this gas the beam would spread out and be useless for observation work. In addition, it increases the sensitivity of the tube, by obviating the use of a very high potential, otherwise necessary for the focusing of the beam. With the high potential the tube loses sensitivity.

### Operation of the Tube

The electronic stream in passing through the pairs of deflector plates is deflected towards the positive plate of the first pair to an extent depending upon the momentary electric field set up by the potential difference between the plates of that pair. A second deflection at right angles to the first will take place when the beam reaches the second pair of plates, if a difference of potential exists between the plates of this pair. The final result is that at any moment, the end of the electronic beam occupies a position on the viewing screen, which is in direction and distance from the normal position of the spot, the result of the deflecting potentials applied to the two sets of plates. As an illustration of the effect of the deflector plates upon the electronic stream, we show in Fig. 2-A the viewing screen with the recording point of the electronic beam. Without any A. C. potentials applied to the plates other than the regular 300 volts D. C. required for the operation of the tube, the image on the screen would be a small sharp spot, the sharpness of which is governed by the cathode or filament current. If we now apply an A. C. potential to one

set of plates, the spot will change its shape to that shown in Fig. 2-B. If we apply this same potential to the other set of plates the spot will assume the position shown in Fig. 2-C. Figs. 2-B and 2-C show how the image on the screen is changed when one

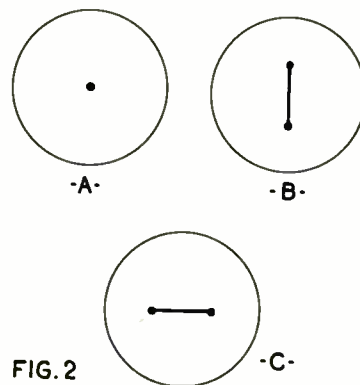

FIG. 2

A is image on viewing screen with no applied A.C. potential. B and C are the images created when an A.C. potential is applied to one or the other set of deflecting plates.

potential is applied alternately to either set of plates. As the deflecting field between the plates of each pair vary with the phenomenon under observation, the spot on the screen varies in accordance with the variations in the phenomenon.

### Uses of the Tube

The field of utility of the cathode ray tube is very extensive, covering subjects far beyond the scope of the average radio service man, but it will be found of excellent service in the field of study and of interest to the scientific service man. The following is a partial list of the types of investigations possible with this tube.

1. Measurement of waveform of alternating currents.
2. Measurement of phase relations of alternating currents.



FIG. 4

Suggested layout for housing the tube and controlling equipment.



3. Study of current to voltage relations in electrical apparatus.
4. Characteristics and properties of electrical oscillation generators. (Vacuum tubes.)
5. Measurement of corona effects along electrical lines.
6. Detection and measurement of atmospheric static.
7. Accurate frequency comparisons.
8. Measurement of dielectric constant.
9. Measurement of power factor, dielectric strength.
10. Measurement of inductance and capacity.
11. Measurement of the amplifying powers of amplifiers.

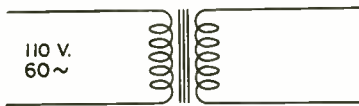

FIG. 6A

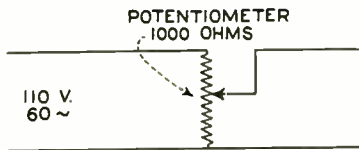

FIG. 6B

Step-down transformer connected to lighting line to obtain low voltage, and potentiometer circuit for making comparisons.

12. Measurement of the amplifying power of tubes, transformers, etc.
  13. Measurement of the amplifying characteristics of all coupling units.
- In all, a field broad enough to fully

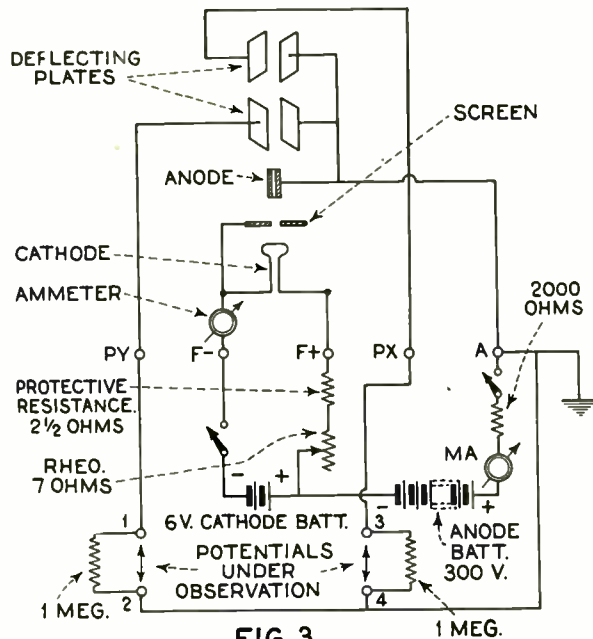

FIG. 3

Circuit diagram of the time axis producer connected up to the oscillograph tube. The frequency and speed of the time sweep is altered by changing the filament temperature of tube V<sub>2</sub> which controls the oscillators V and V<sub>1</sub>.

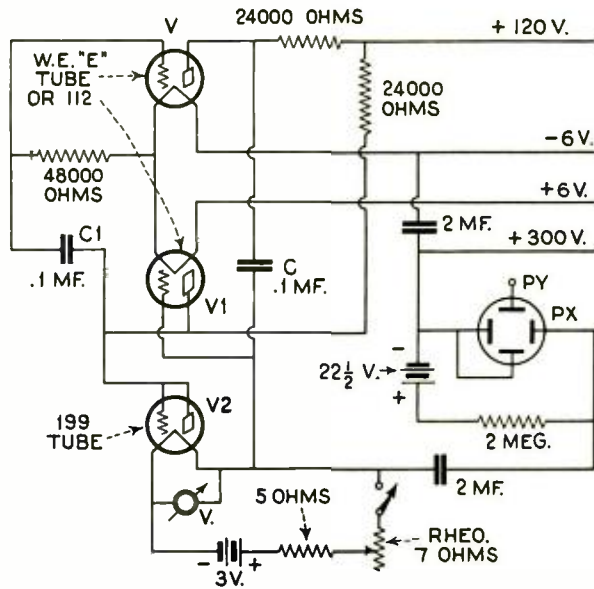

FIG. 5 & 6

justify the installation of the equipment. In this respect I speak from personal experience, not hearsay. I have two such units in operation in my laboratory, and as a laboratory unit both for experimental and educational research it is "ne plus ultra."

### Installation

Many will doubtless be surprised to hear that the installation of the cathode ray tube for general experimental work is simple and comparatively inexpensive. While it cannot be put to satisfactory use by the tyro

radio fan, the average experimentally inclined radio man, with a fair knowledge of radio phenomena will be able to utilize this tube to good advantage. The research worker and professional radio man with an inclination towards experimental radio will find this tube to be the greatest aid in his work. The scientific service man will find this tube of great aid, particularly in audio frequency work; in fact he will be in a position to make observations otherwise impossible, unless he possessed other costly equipment.

As to the equipment necessary in conjunction with this tube, the following is the list of component parts.

First the 224A cathode ray tube. A source of voltage and current for heating the cathode or filament. A storage battery is necessary, since the filament current drain varies from 1.3 to 1.7 amperes at a filament potential of approximately 2 volts. In view of the fact that a rheostat is required for the adjustment of the filament potential, it is best to use a 6 volt storage battery, thus assuring satisfactory filament current and voltage. The adjustment of the filament current is critical since the sharpness of the focus is governed by the filament brilliancy. The filament circuit consists of a switch, a 2.5 ohm fixed protective resistance and a 7 ohm rheostat. The plate or anode potential is 300 volts although the tube has been designed to operate over an anode potential range of from 250 to 400 volts. The tube loses sensitivity as the plate voltage is increased, but the brightness of the spot increases as the plate voltage is increased above the minimum value. But 400 volts should be the maximum plate voltage. The source of anode potential should be either a bank of "B" batteries or a good rectifier filter system. "B" batteries may

The oscillograph tube connected up for operation. With this permanent layout a great many tests can be conducted. For some tests, special apparatus is required which is used in conjunction with this circuit, as explained in the text.

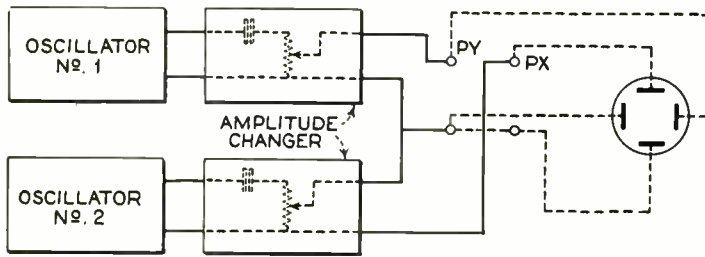

FIG. 8

The method of arranging an audio oscillator to be calibrated against a known frequency, for the purpose of matching frequencies.

be used, since the plate current drain varies between .5 and 1 mil. If a rectifier-filter system is employed it is important that the plate voltage source should be one which will not have momentary fluctuations greater than one per cent. The equipment necessary for the operation of the tube are shown and mentioned in Fig. 3. This is the wiring diagram of the tube. The mounting of the tube and the control equipment is shown in Fig. 4. The control equipment is mounted on the panel on the left and on the base board joined to this panel. The tube itself is contained within the chamber on the right. While the fluorescent spot can be observed in bright daylight when it is stationary, observations of the spot in motion must be made in a dark room. But if the tube is used as shown and a cover is placed over the opening of the housing, with proper eye apertures, all external light will be excluded from the chamber when the observer is operating, and observations will be possible in broad daylight. The filament ammeter and the plate milliammeter are important, for reference adjustments. In addition, the filament ammeter serves as a guide when adjustment of the filament current is being made.

**Using the Tube**

If all the equipment necessary for the operation of the tube is available and has been interconnected so that the tube may be set into operation, the following is the procedure. Adjust the filament rheostat so that all the resistance is "in." Close the filament switch and adjust the filament rheostat so that about 1 ampere is flowing through the filament. Now apply the plate voltage.

If it is approximately 300 volts, plate current will not be indicated on the plate milliammeter. Now slowly increase the filament current until 1.3 amperes is flowing through the filament. The plate milliammeter will now indicate a small value of plate current. Now observe the sharpness of the spot on the screen. Slow manipulation of the filament current control is important since before and after the correct adjustment has been reached the image will appear diffused,

Nothing is to be gained and everything is to be lost by applying more filament current than is necessary to produce a clear, sharp spot. Under

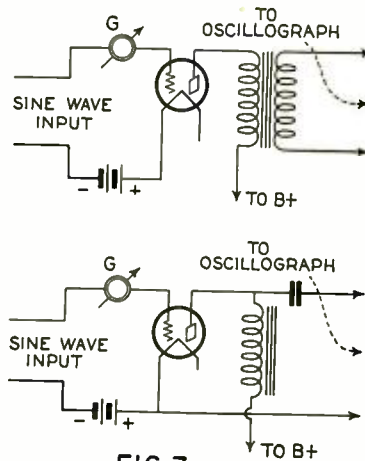

FIG. 7

Circuit arrangement for studying the effect of an overloaded vacuum tube in an A.F. amplifier, using an output transformer or output impedance.

normal conditions, the spot will be in the exact center of the screen, but in some instances, because of the earth's magnetic field and misalignment of the deflecting plates, the spot

will not be in the exact center. It can be brought to the exact center by orienting a strong permanent magnet outside the tube until the spot is correctly located. The magnet can then be permanently fastened in position. In order to manifest the smallest amount of effect upon the electronic beam, it is imperative that the tube itself be removed from the fields of generators, alternators, transformers, etc.

The tube is not purely an electrostatic device, but possesses a certain value of impedance, which value, however, is high enough to be negligible in most cases.

The magnitude of the deflecting potential must in all cases be such as to give a convenient deflection. If it is excessive, and the image is off the screen, the deflecting potential will have to be reduced with an amplitude changer. This will be discussed later. When either set of plates is not being used, the individual plates of that pair should be connected together, to preclude any deflection of the beam when passing between these plates.

Now, in order to make observations of waveform, which field will be the greatest for the scientific service man, it is necessary to produce a time axis, that is, a potential varying in a convenient manner with respect to time. If the potential (wave) to be observed is applied to one pair of deflector plates, the spot will trace a straight line across the screen. Observation of the waveform of this potential is therefore impossible unless the time axis is produced. This time axis spreads out the line variation so that its action over a fixed period of time may be observed. If the potential is cyclic and the time axis producer is set to vary at the same time periodicity as the phenomenon to be observed, the image will become a stationary pattern upon the screen. Hence a time axis producer is necessary. The wiring diagram for this unit is shown in Fig. 5. This equipment is necessary, and should be constructed when the tube control panel is built. With-

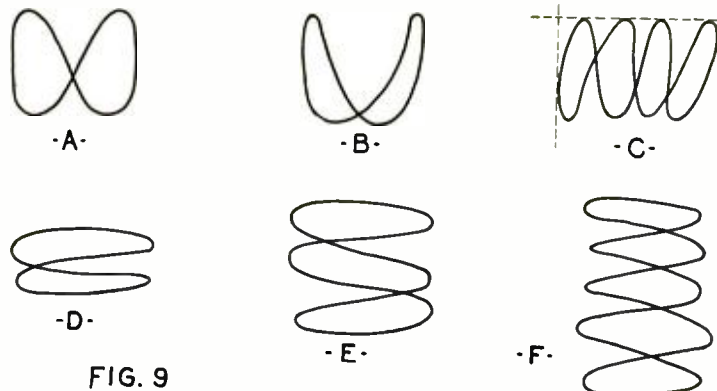

FIG. 9

Some of the figures obtainable in frequency matching tests, using the circuit of Fig. 8 in conjunction with the oscillograph tube.

out it, the utility of the tube is rigidly limited. As a matter of fact, this time axis unit is imperative for our work.

**Time Axis Producer**

There are various systems whereby this time axis can be produced, but the one shown in Fig. 5 is the simplest and obviates all mechanical considerations. The parts required are mentioned in the drawing. In this system, the two tubes V and V1 are symmetrically coupled by the condensers C and C1 and the four resistances. This circuit comprises an oscillating system, and the two condensers are alternately and suddenly charged up to full voltage and then gradually discharged through the filament-plate impedance of tube V2. By varying the filament temperature of tube V2, the filament-plate impedance is varied, and the frequency and speed of the time sweep can be changed over a wide range.

The source of filament supply for the two oscillator tubes used in the time axis unit can be the battery supplying the cathode ray tube. The same is true of the plate voltage for the oscillator tubes. A tap at the 130 volt terminal of the cathode "B" supply will be satisfactory. A separate "A" supply is, however, necessary for the filament of the tube V2. Since this is a low voltage, low current tube, a set of No. 6 dry cells will be satisfactory.

**Making Tests**

Let us now put the tube to use. We will give several examples of the use of this tube. Other uses will be discovered by the operator. Suppose we wish to determine how an audio amplifying transformer or any audio coupling unit will pass a 60 cycle note. The easiest way of obtaining the 60 cycle note is to utilize the regular 60 cycle house lighting supply. But before we can make any tests we must ascertain the shape of the house supply current. We must determine if it is sine. By observing the waveform of the potential as obtained from the house supply and comparing it with the waveform of the output of the coupling unit, we can

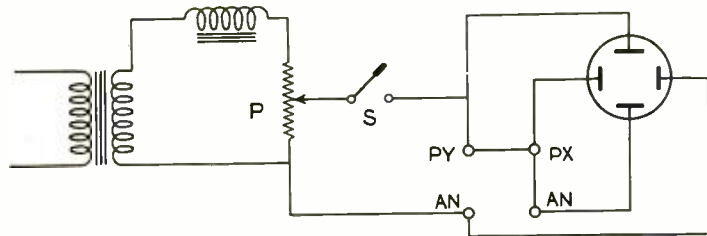
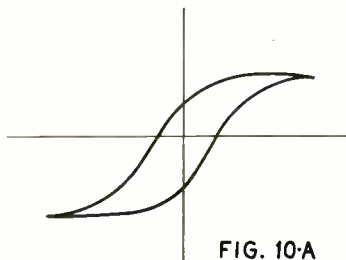

**FIG. 10**

Circuit for measuring magnetic hysteresis losses and obtaining the hysteresis curve of iron or alloys of similar characteristics.

determine if the coupling unit introduces any harmonics. This is particularly true if the coupling unit is being operated in conjunction with amplifying tubes. In order to give us a low voltage we will use a step-down transformer in conjunction with the 110 volt, 60 cycle supply. Incidentally we can compare the wave-shape of the

With the cathode ray tube in operation and the time axis tubes extinguished, the spot will trace a straight line on the screen. The length of this line should be measured with a ruler. The transformer should now be disconnected from the oscillograph tube and the output of the potentiometer connected to the terminals PY and the common anode. The potentiometer should now be varied until the line on the screen is of the length obtained with the transformer. The potential obtained from the potentiometer unit is now equal to the potential obtained from the transformer combination, since the length of the image is governed by the potential being applied to the plate. In this respect the tube can be used as a voltmeter for alternating currents.



**FIG. 10-A**

Hysteresis curve of an iron sample as it appears on the viewing screen of the oscillograph tube.

line supply with that of the output of the transformer. Let us do that. The cathode ray tube and the time axis units are connected as shown in Fig. 6. The transformer is connected to the lighting system as shown in Fig. 6-A. A 1000 ohm potentiometer, capable of carrying 250 mils, is connected across the 110 volt supply as in Fig. 6-B. Let us assume that the step-down transformer is a regular filament lighting transformer supplying 5 volts. We apply the output of the transformer to the terminals PY and the common anode (the midpoint connection to the two grid leaks).

Now the time constant unit is placed into operation and the waveform of the house supply current will be visible on the screen. By varying the filament temperature of the tube V2, the image on the screen can be stopped and a study of the waveform made. Now the transformer combination can replace the potentiometer arrangement and the waveform of the voltage output can again be made.

If one desires to make a study of the effect of an overloaded vacuum tube in an audio amplifying system, the arrangement shown in Fig. 7 can be used. Other systems will suggest themselves as the experimenter becomes more familiar with the operation of the cathode ray tube.

**Matching Frequencies**

Very accurate frequency comparisons may be made with the cathode ray oscillograph tube. This should be of interest to people who have occasion to work with audio frequency oscillators. In operation, one source of alternating voltage is connected to one set of plates and the other source of alternating voltage is connected to the other set of plates. (When making frequency comparisons, the time axis unit is disconnected.) If the two alternating voltages bear some simple ratio in frequency the pattern upon the screen will appear stationary in the form of a Lissajous figure. When making frequency comparisons, one source of alternating potential is of a

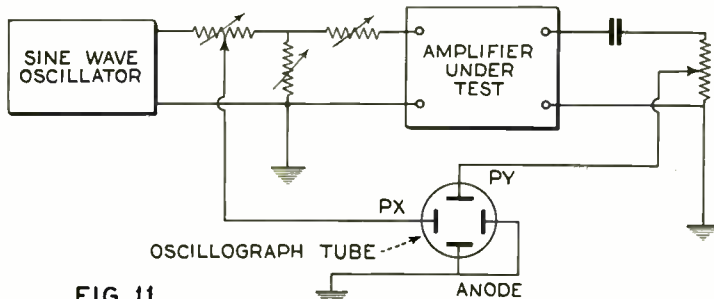

**FIG. 11**

Test circuit for determining the power handling ability of an A.F. amplifier by observing the phase relation between the input and output voltages.

known frequency. The method of arranging an audio oscillator to be calibrated against a known frequency of say 1000 cycles is shown in Fig. 8. The 1000 cycle note should be sine. The amplitude changes are conventional potentiometers similar in arrangement to that used in the 110 volt house current test. These amplitude changers are necessary only in case the applied potential causes an image which spreads beyond the limits of the screen. Getting back to the audio oscillator, whose output should also be sine, we are ready for the calibration work. Let us assume that a known frequency of 1000 cycles is applied to one set of plates. An approximate setting of the audio oscillator is made at 200 cycles and close adjustment results in a stationary image similar to that of Fig. 9-A or 9-B. The frequency of the audio oscillator is now raised until the pattern similar to that of 9-C is obtained. This shows a 4 to 1 ratio. In other words, if the known

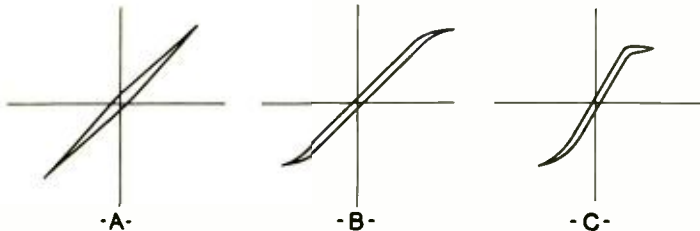

FIG. 12

Phase relation curves of an audio amplifier. Curve A shows satisfactory operation while curves B and C indicate overloading.

frequency is 1000 cycles, the adjustment of the audio oscillator is 4000 cycles. The ratio of the two frequencies can be determined when the pattern is stationary by drawing two straight lines tangent to two adjoining sides of the figure. The ratio of the number of points at which these lines are tangent to the peaks of the loops on the two sides is the frequency ratio of the two voltages. For example, in figure 9-C, the ratio of the loops which touch the tangents is 4 to 1. It will be found possible to calibrate in this manner until a ratio of 12 to 15 is reached.

With the known frequency left intact, the figure will assume a different shape if the unknown frequency is less than the known. That is, the Lissajous pattern will still remain but in a different alignment. For example, in Fig. 9-D-E and -F we have ratios of 1 to 2, 1 to 3 and 1 to 5. In other words the frequency of the audio oscillator under test was 500 cycles, 333 cycles and 200 cycles respectively. A very interesting phenomenon will be observed when one frequency differs slightly from that of the other. In this case there will be a varying phase relation, and the Lissajous figure on the screen will appear to rotate slowly. The greater the difference between the two frequencies, the faster will this image rotate.

### Photographing the Image

A stationary pattern on the screen can be photographed by the average camera. I used a Graphlex with a 6.3 opening, 10 minute exposures and obtained some excellent stills. If desired, a pattern of the image can be traced on transparent paper, if the paper is placed upon the flat end of the bulb. If this paper is thin graph paper excellent records can be obtained.

### Electric Sensitivity

The theoretical formula covering the operation of the tube and the deflection Y of the spot and the potential P between the plates, with the geometrical constants of the tube is

$$Y = \frac{P L_1 L_2}{2 VD}$$

Here V is the potential between the filament and the anode, D is the separation between the two deflector

plates. This deflection is proportional to and in phase with the current and therefore the magnetizing field. The resultant figure on the screen will be a curve similar to that shown in Fig. 10-A. The time axis may be produced by first opening switch S and then closing the switch and removing the solenoid and the iron sample.

### Testing an Audio Amplifier

The power handling ability of an audio amplifier can be tested with the cathode ray oscillograph tube by observing the phase relation between the input and the output voltages. If the amplifier is operating satisfactorily the curve showing phase relation will be a narrow ellipse, but if overloading is occurring in the amplifier, the tops of the waves will be flattened, and the image on the screen will change its shape. The test circuit is shown in Fig. 11 and the curves of Figs. 12-A and 12-B and 12-C show satisfactory operation and two instances of overloading. The greater the overloading in the amplifier the greater the horizontal portion of the ends of the curves. In this test it is important that the input wave be sine.

Additional information about the cathode ray oscillograph tube will be given in the near future.

## Radio Holds Attention of 90 Million People

APPROXIMATELY 90,000,000 of the 1,000,000,000 people living within the world's constant radio reception area receive radio broadcast programs, in some form according to a report on potential markets for receiving sets by Lawrence D. Batson, Electrical Equipment Division, Department of Commerce.

About 18,000,000 receiving sets are now in use, according to Batson, who estimates that 200,000,000 sets would be required to service all of the people within the constant reception area on a basis of five members to each family.

Fifty-seven foreign countries now maintain regular broadcast service with Canada, Cuba, Russia, Sweden, Australia, Germany, United Kingdom, Argentina, and Mexico ranking first in order of number of broadcasting stations maintained and regularly operated.

Radio broadcasting, according to Batson, has attained as great importance in international, national, and family life abroad as it has in the United States, all circumstances considered, and has now been recognized by all of the principal foreign governments as an important means of disseminating entertainment, information, and instruction.

Radio programs have a striking similarity all over the world and it is not without some basis of possibility that programs broadcast throughout the whole universe may be expected to prove more popular than those of local origin.

plates of one pair, L1 is the length of the plate in the direction of the beam and L2 is the distance from the center of the pair of plates to the screen. The units are volts and centimeters. In this oscillograph tube (the 224A) L1 is 1.27 cm L2 is about 20 cm. The distance between the plates is .475 cm. With the operating potential at 300 volts the potential difference between the plates needed to produce a deflection of 1 cm. is about 11 volts. The capacity between a pair of deflector plates is approximately 10 mmfds.

### Measuring Magnetic Hysteresis

Fig. 10 shows a method of measuring the hysteresis losses and a method of obtaining the hysteresis curve. The same to be tested is placed inside of a solenoid with one end close to the side of the tube. (The time axis unit is not used in this test). An alternating current of the desired frequency and of sufficient magnitude to produce a magnetizing field of sufficient strength to deflect the beam, is passed through the solenoid. The field from the iron deflects the beam in proportion to the induction. Simultaneously a deflection proportional to the magnetizing field and at right angles to the field is obtained from the voltage drop across the potentiometer P in series with the magnetizing sole-

# The Use of Measuring Equipment

Utilizing the equipment previously described

By E. W. D'Arcy\*

## PART III

### Measuring Capacities

WITH the equipment described, this is a very simple thing to do. The bridge is connected as in Fig. 1. The condenser to be measured is connected across the secondary inductance. The frequency of the driver circuit is then varied until it is at resonance with the inductance and condenser, at which point the vacuum tube voltmeter will show a maximum deflection. The switch is then thrown over and the standard capacity unit connected across the inductance, and it is then varied until a maximum deflection of the vacuum tube voltmeter is noted. The capacities then are equal, and the capacity of the standard condenser will equal that of the condenser being measured.

### Measurement of Distributed Capacity of Inductances

A bridge of this type greatly facilitates measuring the distributed capacities of an inductance. This measurement makes use of the circuit diagram shown in Fig. 2. This system uses a plot of the wave length squared against the condenser capacity. Since

$$\lambda = 1.885 \sqrt{L(C+Co)}$$

$$\lambda^2 = 3.553 L(C+Co)$$

Since L, the pure inductance, is a constant, the relation between wave length squared and C is linear, and the plot will be a straight line as in Fig. 3.

The slope of this line  $\frac{d(\lambda^2)}{dC} = 3.553 L$  determines the pure inductance of the coil. The distance from the origin to the intercepts of the line with the axis of abscissae determines the capacity of the coil, for when  $\lambda^2 = 0$ ;  $C = -Co$ . In operation, the standard capacity condenser is adjusted to its maximum capacity and

\* Engineer, Dar-Mac Laboratories.

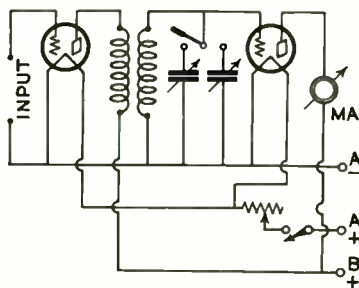

- FIG. 1 -

Circuit arrangement for measuring unknown capacities.

then connected across the inductance. The capacity is then reduced uniformly, that is, readings are taken, if the condenser capacity is .001 mfd. maximum, at .0009, .0008, .0007 mfd. These readings are then marked down on graph paper and plotted against the wave length squared, that is, when the condenser is set at .0009 mfd. the driver circuit is varied until resonance is indicated by a maximum deflection on the vacuum tube voltmeter. The frequency of the driver is then noted and this gives us the wave length squared.

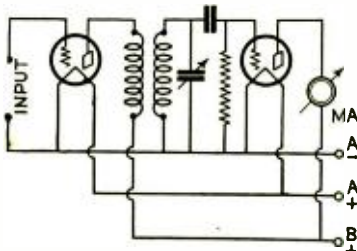

- FIG. 2 -

Circuit employed for measuring the distributed capacity of inductances.

### Measurement of Capacity Between Primary and Secondary of Audio and Intermediate Frequency Transformers

This is a very simple measurement to make and oftentimes tells us the reason for an unselective super. In superheterodyne transformers, where no attempt is made to reduce the capacity between primary and secondary, there is quite likely to be a capacity coupling effect across the entire amplifier system, and if local signals are sufficiently strong, they will be rectified in the first detector and then amplified by the intermediate frequency amplifier as an audio frequency current.

In measuring the capacity between primary and secondary of a transformer, the same kind of a circuit is used as in Fig. 1. We have our known capacity, and at the other switch position we have one end of each inductance connected. The hook-up is shown in Fig. 4.

In operation, the driver and bridge are started, the capacity switch arm is thrown to the off position, a note is made of the frequency to which the inductance alone responds. The switch arm is then thrown to the transformer, whose primary and secondary capacity is being checked. The driver's frequency is then varied until maximum response is indicated in the vacuum tube voltmeter. The

switch arm is then thrown to the standard capacity being used, and it is varied until the vacuum tube voltmeter indicates that this circuit is at resonance. The capacity indicated by the standard capacity is the primary to secondary capacity of the transformer under test.

### Measuring Minute Voltages

By calibrating the vacuum tube voltmeter used in the bridge and connecting the bridge up in some such circuit as shown in Fig. 5, it is possible to measure extremely minute voltages. A resistance is used, and the principle being employed is that, knowing the current through a circuit and the resistance of a circuit, the voltage can be determined at any point of its resistance, providing it is a pure resistance and not a combination of inductance and capacity. This system is used for calibrating the vacuum tube voltmeter. A very accurate calibration can be obtained this way, and makes possible the determination of minute radio frequency voltages.

### Measuring Audio Frequency Transformer Characteristics

The following changes are necessary in the Voltage Amplification Bridge (described in September RADIO ENGINEERING) before audio frequency transformer characteristics can be determined. It is necessary to change the .002 mfd. blocking condenser in the grid of the vacuum tube voltmeter to a 2. mfd. condenser, and instead of using a galvanometer, a 0 to 1.5 milliammeter should be used. This is all that is necessary to change over the bridge circuit. The driver circuit explained in the August issue of RADIO ENGINEERING must have an audio frequency oscillator inductance installed, replacing the radio frequency oscillator inductance. A de-

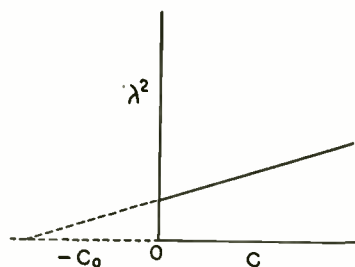

- FIG. 3 -

The mathematical basis for determining the distributed capacity of an inductance, using the circuit arrangement of Fig. 2.

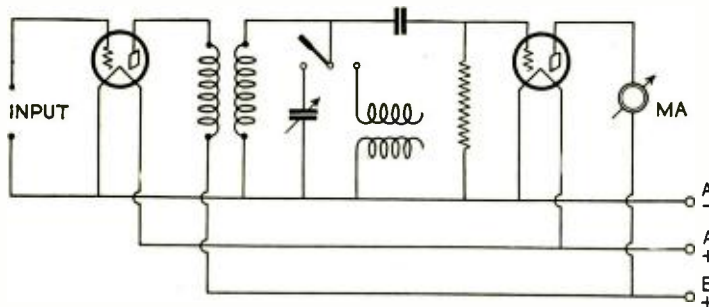

- FIG. 4 -

Circuit arrangement for measuring the capacity between primary and secondary windings of audio and intermediate frequency transformers. This circuit is actually the same as that of Fig. 1.

each capacity block is used to vary the frequency of the driver circuit. The same circuit diagram and instruments are used aside from these minor changes.

This system makes possible the accurate determination of the frequency response of an audio frequency transformer as the tubes simulate the conditions under which the transformers operate. Oftentimes the cause of distortion in an otherwise perfect radio set is due to a defective audio frequency transformer and ordinary tests fail to disclose the trouble in the receiver. By checking over the audio frequency transformer, a very good idea is obtained of the perfectness of construction. If any turns are short-circuited, or a high resistance across the transformer, or a high capacity winding is used in the transformer, it will all show up on the curve drawn of the voltage amplification of this transformer.

**Use of Previously Described Equipment in Broadcasting Stations**

It is surprising to the author that in a large number of the broadcasting stations he has visited, where the equipment has been built at the station, no attempt has been made whatsoever to balance this equipment in a scientific manner. Rather the proprietor or engineer of the station buys standard parts and adapts them to use in his station. This, of course, is perfectly all right and the output of the station might be fair, but considering the type of receivers now being used, a station's output must be very near flawless before it can put any feathers in its hat. The equipment necessary to do this is so relatively simple and the operation of this equipment so simple, that it really is surprising that it has never been used oftener as a standard piece of equipment in the broadcasting station. To illustrate what the author means, we will explain the tests to be conducted in a theoretical station. To begin with, we have the microphone transformer, and as a rule three stages of ordinary amplification. The audio frequency driver is connected up through an impedance matched to the primary impedance of the trans-

former to which the microphone is connected. The voltage output of the driver circuit is kept at a constant level for all frequencies, and the vacuum tube voltmeter is placed to measure the output of this amplifier system. The voltage being kept constant at all frequencies and noting the voltage output from the driver on a piece of graph plotted against frequency, will give us a very good idea of the amount of distortion present in the line amplifier. After this test has been gone through and if the amplifier is defective, it is corrected. Then we can go on with the tests. As a rule broadcasting stations have at least two stages of power amplification ahead of the modulator tubes. A vacuum tube voltmeter is connected to the output of the power amplifier and the same tests made over again. This in turn discloses whether there is distortion present in the power amplification stages. After this test has been gone through, we are ready to check the distortion caused by the constant current choke coil and an antenna system which is too selective. For this test a plate rectification vacuum tube voltmeter is used and is connected across a pick-up coil, which is not tuned to the frequency on which a station is broadcasting, thus destroying any error which might occur from a sharp pick-up system. The transmitter is then started and the same test gone through with. This test checks the total output from a station. However, the test in itself is of no importance unless it is ascertained by

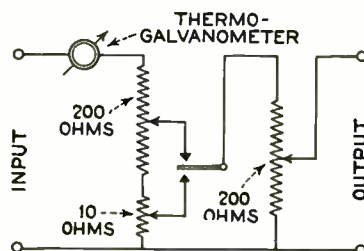

- FIG. 5 -

A circuit for measuring extremely minute voltages such as the voltages in successive radio frequency stages.

tests on all the equipment up to the modulator tubes as to the quality of the amplifier systems. After we know that all of the amplifier systems are not distorting, and the final check-up shows distortion present, we know definitely that we can look for trouble in either the modulator tubes or the constant choke coil. While these tests are rather laborious, at the same time when they are finished, the broadcast station engineer knows just exactly what the output of his station is actually like.

**Broadcast Stations by Numbers**

DESIGNATION. Identification and location on the receiving set of radio broadcast station channels by the simple method of giving them numbers, as well as call letters, is being studied by a special committee of the National Electrical Manufacturers Association, and will form one of the major subjects for discussion and consideration at the meeting of the Radio Division of the Association, to be held at Edgewater Beach Hotel, Chicago, November 28-December 2.

Through a number of technical papers by authoritative experts the program will focus on phases of the radio industry which merit immediate attention from the manufacturer. The subjects include: growth and development of the industry, merchandising, relation of radio to the electrical industry, standardization of radio broadcast program copy, analysis of the broadcast situation with respect to inter-channel and same-channel cross talk and heterodyne interference, and factors bearing on the design of radio products, such as developments and characteristics of A. C. tubes, methods for obtaining economical power supply from house lighting circuits, and future trends in cabinet design.

With reference to numerical designation of broadcast channels, Louis B. F. Rayercroft, Vice President in charge of the Radio Division, in a statement today says, "A striking suggestion by R. H. Langley of the Crosley Radio Corporation, and a member of this Association, has been made to us which might eliminate the confusion which arises over designation of broadcast channels by kilocycle and wavelength.

"These channels as determined by the Federal Radio Commission, might instead be designated by arbitrary numbers, say from one to ninety-six, as Mr. Langley suggests. This would simplify press program announcements, simplify radio receivers, and provide them a convenient and quick way for calibration of receivers for both manufacturer and user."

A committee has been appointed by Mr. Rayercroft to report on the desirability of numbering these channels in the manner suggested.

# Methods of Controlling Volume

*An outline of the advantages and disadvantages of the systems most commonly employed*

*By Charles Golenpaul\**

**T**IMES change. Several years ago, the main thing was how to obtain volume, irrespective of tone quality. Today, most sets are capable of producing more than ample volume, so that the main aim is to cut down the volume when desired, without sacrificing tone quality.

Let us bear in mind at the very start of our discussion on volume control, that the radio receiver is a collection of delicately-balanced circuits—or at least it should be so, if the best results are to be obtained. The values of inductances are usually quite critical, so that any change in the inductance of one circuit may unbalance the receiver and result in distortion. For this reason, therefore, the volume control should be of the non-inductive type so that there will be no change in inductance value as the result of a change in resistance.

The cardinal principle in controlling loud-speaker volume, aside from the use of a non-inductive resistance, is to begin as soon as possible in the receiving process. In other words, the nearer the antenna end that the control is put into effect, the better the results and the simpler the control; and vice versa, the nearer the loud-speaker end, the more energy must be handled by the variable resistance and the more likelihood of distortion.

## *Control in Antenna Circuit*

The simplest volume control is a variable high resistance in the antenna lead, which serves to cut down the signal energy, and is of real value especially when intercepting powerful local stations. Some times the variable high resistance may be shunted across the antenna and ground binding posts of the set. At any rate, with a suitable non-inductive variable resistor a simple and undistorted volume control is obtained for any receiver. The resistance range must be from practically zero to several million ohms in the case of the resistor placed in the antenna lead, which appears to be the better of the two arrangements.

Now if we do not control the energy at the very entrance to the radio set, the next best bet is to control it as soon as possible in the radio-frequency stages. Here the best practice is to place the variable resistor in the plus "B" 90-volt lead, so as to control the plate current of the radio-frequency tubes and therefore the energy passed on to the detector tube. It is also possible to control oscillation by means of a variable high resistance, but in this case a fine adjustment variable

resistor—one that has an absolutely gradual adjustment of resistance—is essential. The resistance should be of the order of practically zero to some 500,000 ohms, in providing the necessary wide adjustment.

## *Volume and Sensitivity Control*

With a volume control in the plate circuit of r.f. tubes, it becomes possible to employ coils which will normally oscillate at 90 volts on the tubes, with whatever stabilizing method may be used. Then, with variable plate voltage, the receiver can be worked at top efficiency, right on the very verge of oscillating, as well as brought down to a very low efficiency in reducing loud-speaker volume without distortion. We have, therefore, a sensitivity control as well as a volume control, which is ideal in present-day reception.

## *Regeneration Control*

If the set is of the regenerative variety, the regenerative action is the obvious thing to control, and this may be readily done without having to fuss with the critical tuning means which can be left fixed at the desired point of maximum efficiency. The volume control may consist in this case of a precise variable resistor of at least 0 to 500,000 ohms resistance, shunted across the terminals of the tickler or feedback coil. Needless to say, only the non-inductive type resistor can be used. If desired, the set can be tuned to full oscillation, with the variable resistor serving to by-pass more or less of the feed-back energy in getting down below the oscillating point with razor-sharp precision. This is a most popular method of controlling regeneration, and likewise volume, especially in the critical short-wave receivers.

The non-oscillating detector may also be controlled by means of a variable high resistor in the plate lead, especially if 90 volts is applied to the detector so as to have plenty of margin in cutting down to the desired volume. Most of the present-day detector tubes, being of the high-vacuum type, work best with higher voltage than the former soft or gassy detector tubes.

So far, we have been dealing with minute currents, so that a light-duty variable resistor can be employed, provided it maintains its adjustment without fluctuation to cause noisy reception. There is no reason for employing the larger, heavier and more costly variable resistors for such applications.

## *Controlling Volume in A.F. Circuit*

In going into the audio-frequency field of reception, we begin to en-

counter real power. Still, the volume can be controlled at the secondary of the first transformer, by means of a variable resistance shunted across it. This variable resistance has the further advantage of matching up the characteristics of the two transformers of the usual amplifier, so as to obtain a more uniform amplification curve. In the case of resistance coupling and impedance coupling, a potentiometer arrangement is more desirable, as a rule, but it is good practice to shunt a variable resistor across the input to such an amplifier, by-passing more or less of the energy delivered by the detector.

The next and last place for controlling the volume of the receiver is to shunt a substantial variable resistor across the loud-speaker terminals. Here again, a non-inductive variable resistor must be employed, and since there is often considerable energy to handle, a substantial device must be employed. Even the largest loud-speaker, taking the output of a push-pull amplifier using 210 type tubes, can be readily and safely controlled in this manner, although once more we make it plain that a better control can be had by going back to the r.f. end of the receiver.

The usual radio power unit is provided with variable voltage controls, but these are not intended primarily for altering the volume of the set. They are meant to establish a balance with the circuits and the tubes of the receiver. Once that balance is attained, these controls should be left alone. Other means of volume control should be employed in the receiver itself or at the loud-speaker, as above outlined.

## *Conclusion*

From all standpoints, the use of a variable resistance in series with the antenna lead is probably the most satisfactory means of controlling volume. Furthermore, this method controls the sensitivity as well as the volume and is of considerable value in this respect since it is possible to prevent the detector tube from being overloaded by local, high power stations.

Obviously, it is equally true that one or more variable resistances employed in the "B" leads of the tuned radio frequency amplifiers will allow one to alter both the volume and the sensitivity in much the same way as a variable resistance in the antenna lead, but it is hardly as convenient a method as the latter unless the variable resistance or resistances are to be employed for the stabilization of the radio frequency stages as well.

\* American Mechanical Laboratories.



**The A.C. Operated Shielded Six**

The A.C.-operated Shielded Six, described in the November issue of *Radio News*, comprises three low-resistance, low-loss tuned-R. F. amplifier stages and a detector; each containing a space-wound radio-frequency transformer, the primary and secondary windings of which are held on a molded bakelite form in such fashion that they are practically air-supported. The grid circuits of all four transformers are identical, as are the characteristics of the four modified-S.L.-P. tuning condensers employed with them. As a result, the tuning adjustments of the second, third, and detector stages being identical, all are operated by a single-control dial simultaneously adjusting the three condensers through the agency of a mechanical link which is free from back-lash. Since antenna characteristics cannot be definitely pre-determined and will vary with every installation, the antenna stage of the Six is tuned by a separate control; and in order to accommodate varying lengths of aerials, a tap-switch is provided, allowing the use of part of whole of the antenna transformer's primary coil.

The audio-frequency amplifier consists of two stages employing large heavy transformers which provide excellent low-note reproduction with a 5,000-cycle cut-off; resulting in the elimination to a great extent of background noise, heterodyne squeals, and interference. An output transformer is employed, not only to protect the

loud-speaker windings from the high plate current of the last power tube, but also to compensate for poor loud-speaker performance at low frequencies.

Four CY-327 (heater-type) tubes are employed in the three R. F. stages and as a detector.

fier circuit capable of delivering considerably more undistorted power output than will the average 210 power pack employing only one amplifier tube. The CX-371s are not strictly A.C.-type tubes, but are entirely suited for last-stage audio work with direct A. C. excitation of the filaments. The push-pull feature is optional, and the receiver as available in kit form is provided with a straight 171 power output stage which delivers ample volume for the majority of homes. The set illustrated herewith uses the push-pull arrangement.

Power for the receiver is obtained through a power-supply device, which is essentially a very carefully designed "B" socket-power unit incorporating automatic voltage regulation by a glow tube and a special selective filter circuit. This power unit consists of a step-up transformer carrying two 250-volt windings, and an 85-milliamperere fullwave gaseous rectifying tube. The output of this tube is filtered through a single double-section choke coil and a special combination of condensers providing a selective circuit resonant at 120 cycles—the fundamental ripple of the rectified output. The filter delivers to the voltage dividing resistor a total of 220 volts at approximately 82 milliamperes. Of this, a portion is drawn by the glow tube, to be given up to the receiver under the instantaneous demand imposed by strong signals; the remainder goes directly to the plates of the power output tube.

Filament excitation is obtained from three separate filament-lighting wind-

**IMPORTANT NOTICE**

Beginning with this issue, *Radio Engineering* will specify the parts used by the designers of sets reviewed in the Constructional Development Section.

The manufacturers who, by the employment of competent engineering brains and the maintenance of research and laboratory facilities, are doing the worthwhile developmental work in the industry, are entitled to receive editorial mention.

Readers desirous of obtaining the names of the manufacturers of the parts included in past reviews may receive them by sending a request to the Readers' Service Department, *Radio Engineering, Inc.*, 52 Vanderbilt Avenue, New York, N. Y.

Editor

The first audio amplifier is a CX-326 raw A. C. tube, which is entirely suited for first-stage audio work. The second audio stage consists of two CX-371 power tubes in a push-pull ampli-

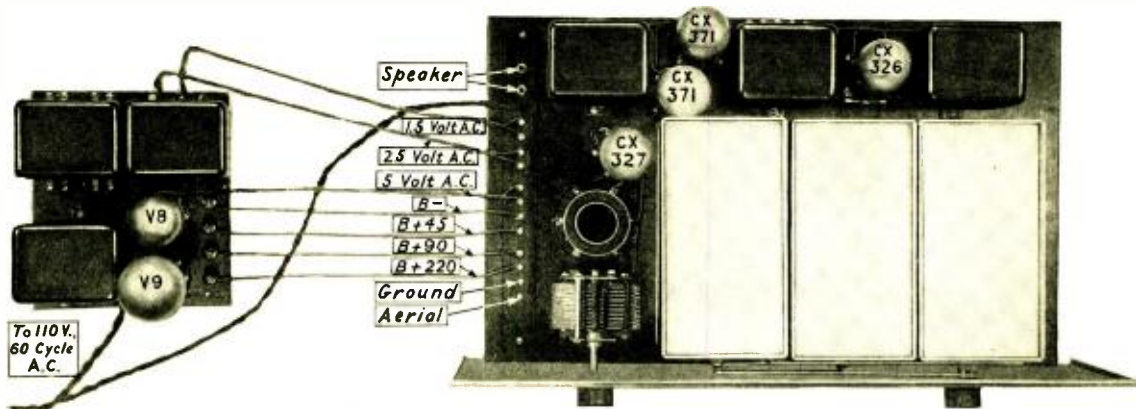

A top view of the A. C. Operated Shielded Six, and the special "A" and "B" power unit to which it is connected. The output audio frequency stage in this receiver is push-pull operated



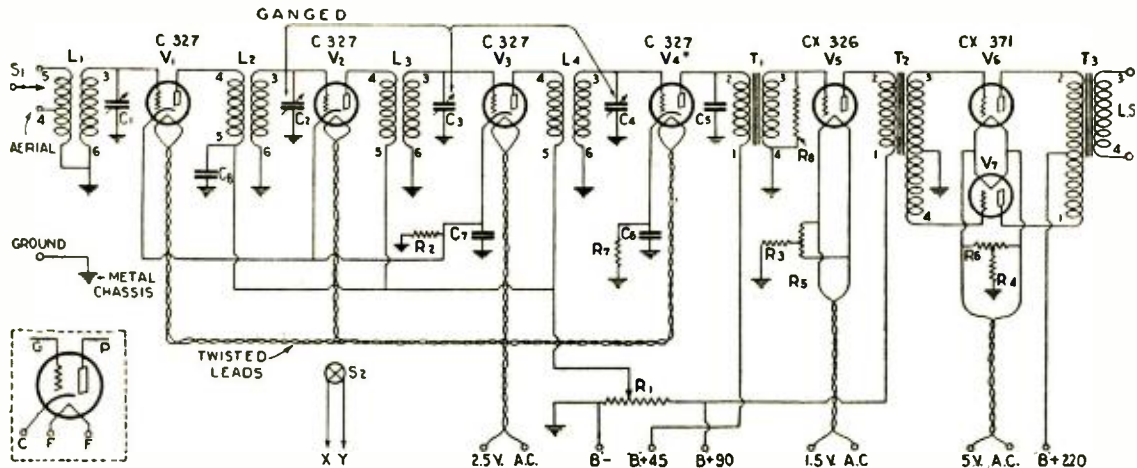

The complete schematic diagram of the A.C. Operated Shielded Six. Take special note of the fact that, with the exception of the A.F. amplifier, A.C. tubes of the heater element type are used throughout. The small diagram in the lower left hand corner shows the tube terminal markings.

ings carried by the power transformer. One winding of 2.5 volts lights the four CX-327 heater tubes; another winding of 1.5 volts lights the CX-326 first audio-stage amplifier; and the third winding of 5 volts lights the CX-371 power output tubes. "C" potential for the various circuits is obtained by means of four resistors inserted in the common grid and plate returns; the voltage drop developed in operation serves to bias the various tube grids to the proper value.

- 1 Silver Marshall No. 636AC terminal strip.
- 1 Silver Marshall front panel (brass) 7" x 21".
- 1 Silver Marshall steel chassis 12" x 19 1/4" x 1 1/4".
- S1-1 Carter S.P.D.T. antenna switch.
- S2-1 Carter on off-switch.
- 1 Kellogg connection wire.
- 1 Polymet resistor mounting.
- R8-1 Polymet 250,000 ohm fixed resistor.
- PT-1 Silver Marshall type 329A power transformer.
- (C1)-1 Silver Marshall type 331 choke coil unit.
- (C2)-1 Silver Marshall type 511 filter condenser.

sary to disconnect the aerial and ground wires from the receiving set proper, and attach them to the two binding posts of the Short-Wave Converter. The detector tube of the receiver is placed in the tube socket of the converter, and the cable plug from the converter is inserted in the detector socket of the receiving set. No other tubes are removed, no battery wires are disturbed, and the loud-speaker remains as usual. The tuning controls on the receiving set itself are not used. The tuning is all done from the one dial of the converter.

The device in reality is a short-wave set, comprising a regenerative detector and an attachment plug for connecting it to the audio end of the present receiving set and to the battery supply.

This method of connecting the two units together is novel. It consists of a five-conductor cable (two leads not used) and an old vacuum tube base for the plug. The glass of the detector tube is broken off and the base cleaned out. Three wires from the cable are soldered to the terminals inside the base, one to the "A" plus, one to the "A" minus, and one to the plate terminal.

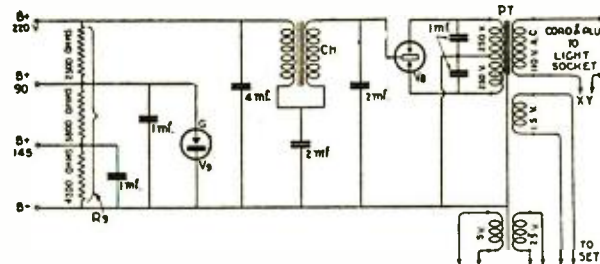

Schematic diagram of the special "A" and "B" power unit for the A.C. operated Shielded Six. V8 is a voltage regulator tube.

- LIST OF PARTS REQUIRED**
- C2, C3-2 Silver Marshall type 316A variable condensers.
  - C1, C4-2 Silver Marshall type 316B variable condensers.
  - L1-1 Silver Marshall type 116A tuning coil.
  - L2, L3, L4-3 Silver Marshall type 118A (matched) tuning coils.
  - 3 Silver Marshall Stage shields.
  - 4 Silver Marshall coil sockets.
  - V1-4-4 Silver Marshall 5-prong tube sockets.
  - V5-7-3 Silver Marshall standard tube sockets.
  - T1-1 Silver Marshall A.F. Transformer.
  - T2-1 Silver Marshall Push-Pull input transformer.
  - T3-1 Silver Marshall Push-Pull output transformer.
  - 1 Silver Marshall triple link for variable condensers.
  - C5-1 Carter .002 mfd. fixed condenser.
  - R1-1 Carter HW6000 potentiometer.
  - LS-2 Carter tip jacks.
  - R2-1 Carter H1600 fixed resistor.
  - R3, R4-2 Carter H1000 fixed resistors.
  - R5, R6-2 Frost PT64 tapped resistors.
  - R7-1 Mountford 5,000 ohm fixed resistor.
  - 2 Martin-Copeland vernier dials.

### A Short-Wave Converter

For the radio fan who wishes to explore the short-wave band from 15 to 125 meters, several ways are provided. However, the plans thus far advanced require changing the connections of the present broadcast receiver to suit requirements of the short-wave set.

Any radio receiving set may be converted instantly, and at will, into a short-wave receiver by the use of the Short-Wave Converter designed by Perry S. Graffam. It is only neces-

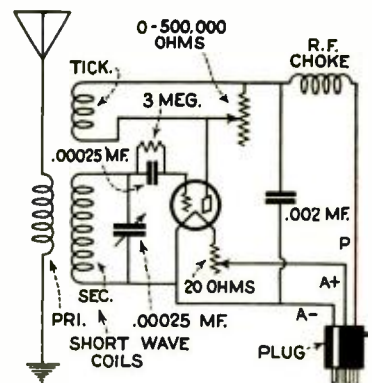

Schematic diagram of the Short Wave Converter.

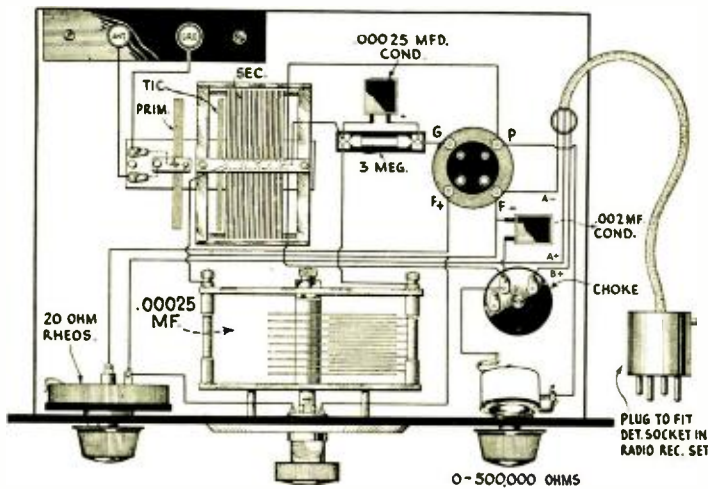

Layout of parts and wiring diagram for the Short Wave Converter. The connecting plug is made from an old vacuum tube base.

Another feature of the short-wave converter worthy of mention, although not new, is its effective regenerative control. A 0-5,000,000 ohm variable resistance is used for this purpose. Not only does it serve as a smooth and continuously variable control of great aid in receiving short waves, but it also saves one tuning condenser. In the circuit this resistance is connected across the plate or tickler coil.

A condenser of especially low minimum capacity is used to tune each secondary coil in the converter, and with a set of three coils this condenser will tune over a wave band extending from 15 to 200 meters. A vernier dial is a necessity on the tuning condenser, as the tuning will be found extremely sharp.

The accompanying layout and wiring diagram give the necessary details of arrangement and wiring.

The choke coil is very important and must not be omitted. When bypassed with a .001 mfd. condenser, it will permit the plate lead to be of sufficient length to reach the receiving set. If a choke coil cannot be easily secured, one can be made by winding 100 turns of No. 26 DCC wire at random on a wooden spool 1/2 inch

in diameter with a 1/4-inch wooden core.

To operate the Short-Wave Con-

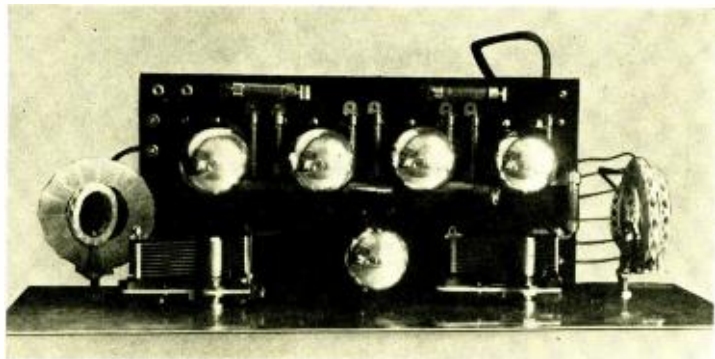

A top view of the Improved Aristocrat Receiver. Note that the antenna coupler has a variable primary coil.

verter, the plug made from the old tube base just as if it were a tube. When the antenna and ground connections have been changed to their respective posts on the converter, you are ready to listen in. To do so, simply leave the loud-speaker where it is, or if phones are used, these may be plugged in as usual in any stage for which a jack is provided on your particular set. Turn the variable resistance across the tickler coil, until the receiver oscillates. Tune in a station and clear up the signal by a further adjustment of the variable resistance or rheostat, as required.

LIST OF PARTS REQUIRED

- 1—20-ohm rheostat.
- 1—.00025 mfd. National electrolyte condenser.
- 1—3-megohm Electroad grid leak.
- 1—Eby standard socket.
- 1—National type C vernier dial.
- 1—Aerovox .00025 mfd. mica condenser.
- 1—Aerovox .002 mfd. mica condenser.
- 1—Set of short wave zero coils.
- 1—Silver Marshall choke coil, No. 275.
- 1—Bradlett 7-foot cable.
- 2 X-L push type binding posts.
- 1 Standard type Chromostat (0-5,000,000 ohms).
- 1—Hard rubber or bakelite panel (7 x 12 x 3/16).
- 1—Wooden baseboard (7 x 11 x 1/2).
- Screws, wire and solder.

verter, remove the detector tube from the regular broadcast receiving set and place it in the tube socket of the converter. Next select the plug-in coil covering the wave band in which you wish to receive, and plug it into the coil jacks. Then insert in the detector tube socket of the regular broadcast

The Improved Aristocrat

Mr. Arthur Lynch has, for a long time, insisted that it is possible to produce the necessary material for a more than ordinarily good receiver, employing real engineering, so that the material necessary for building it could be purchased at retail—and not cut prices either for between \$25.00 and \$35.00. The notion was that the material would be of the highest grade and still be available to the man of limited financial resources.

A few years ago he designed a receiver which was known as the "Aristocrat." It was described in *Radio Broadcast* month after month and became one of the most satisfactory receivers ever described in that magazine. Even though it was a mighty fine receiver and every effort had been made to hold the price down, it would cost a little more than \$60.00 to purchase the parts. The problem was to cut the cost without detracting from the excellent qualities of the receiver.

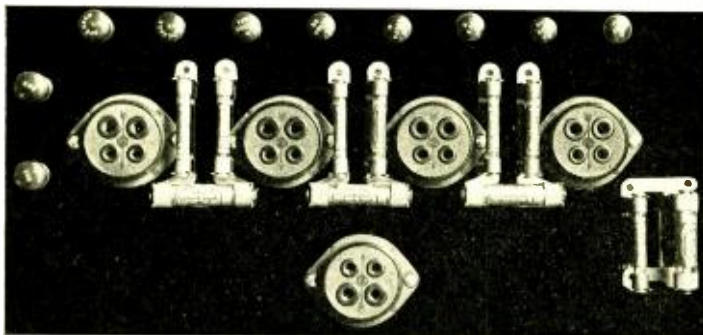

A view of the special deck designed for the Improved Aristocrat Receiver. This includes a three stage resistance coupled audio frequency amplifier.

It was decided to have a manufacturer turn out the sub-panel with all the parts on it. That cut the cost way down and cut the work for the home constructor down to a minimum. At the same time these advantages were

- 1—Wireless radio front panel, including dials and mounting brackets.
- 4—Binding posts (Ant. Grid. and Output).
- 1—Birnback G-wire battery cable.
- 1—Ceco type K r.f. tube.
- 1—Ceco type H detector tube.
- 2—Ceco type G high-mu tubes.
- 1—Ceco type F semi-power tube.

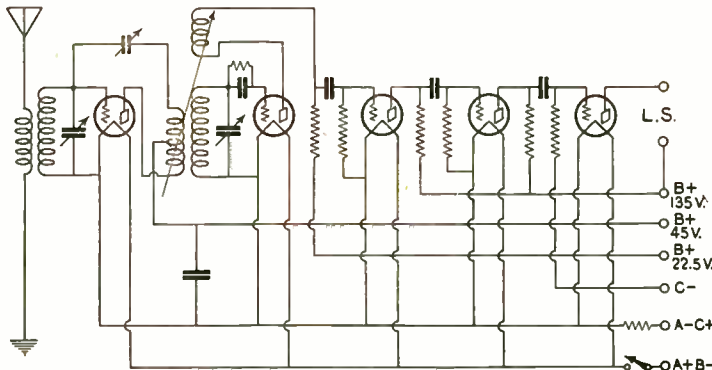

The schematic diagram of the Improved Aristocrat Receiver. Although not indicated, the antenna coupling is variable.

realized other engineering features of merit other engineering features of merit were utilized and the sum total result is a unit which is called a "deck".

The "deck" is a sub-panel with everything necessary for making a five tube receiver mounted right on it—except the tuning elements. There are five of the latest type sockets; all the coupling condensers and resistors for the latest type resistance amplifier held in place by a new type of clip which insures perfect contact.

Holes are provided in the deck for ten binding posts. The posts, however, are not part of the deck equipment because some constructors will wish to use a cable for the battery connections.

The new deck may be used with any one of the whole group of circuits and will, regardless of the circuit employed, deliver very much better than average tone quality because of the resistance coupled amplifier which it has been made to include.

As will be seen from the diagram, the Improved Aristocrat circuit consists of one stage of tuned, neutralized radio frequency amplification, a regenerative detector and three stages of resistance coupled audio frequency amplification. The amplifier is designed to employ a semi-power tube, of the 112 type, in the output with 135 volts "B". If desired, the "B" voltage can be raised to 150 or 180 with a proportionate increase in the "C" voltage on the semi-power tube, or a 171 tube can be used with 180 volts "B" and 40½ volts "C." But in this case, it is necessary to use an output filter or output transformer to protect the loud speaker from the high directed current flow.

**LIST OF PARTS REQUIRED.**

- 1—Lynch deck, complete with sockets resistors and fixed condensers.
- 1—Pair Slickles coils.
- 1—Cogswell type A variable condenser.
- 1—Cogswell type B variable condenser.

frequency oscillation erstwhile "motor boating" is very often due to voltage fluctuations.

In the design of the "Constant Voltage 'B' Eliminator," designed by John F. Rider, great consideration was accorded the subject of voltage fluctuation and every effort was made to reduce these fluctuations to a minimum. It is for this reason that the design of this unit incorporated the "Glow" tube, a tube designed to keep a constant voltage across two points connected to it. The operation of this tube, however, is not limited to the control of voltage fluctuations occasioned by momentary changes in line voltage. In addition this tube keeps the voltage constant within certain values of current drain. In the conventional "B" eliminator, the voltage at any tap is governed by the drain upon that tap. If the current drain is increased beyond a certain value, the voltage available at that tap will be reduced. But with the glow tubes this is impossible within certain limits; limits which are large enough to cover the average use of the eliminator unit. By using a glow tube to control the 90 volt tap and another tube in series to control the 180 volt tap, constant voltages are always available from these two voltage terminals.

Another salient feature of the "Constant Voltage 'B' Eliminator" is the use of a filter system consisting of a single-section of tuned filter and a section of brute force filter. This arrangement is far superior to two stages of brute force filter because the filter action is much better. The tuned stage is tuned to the frequency of the charging current in the output circuit of the rectifying tube, which in this case is 120 cycles. The brute force section on the other hand operates in the elimination of the harmonics.

The voltage taps are located so that 45, 90 and 180 volts are available. The percentage of A. C. component remaining in the D. C. output is exceptionally small. (This is due to the use of the tuned section in the filter).

The reason for the design of only a "B" eliminator rather than a combination of "B" and "C" is found in the fact that the cost of the equipment necessary for the "C" elimination is in

**A Constant Voltage "B" Eliminator**

One of the most important features of a "B" eliminator is the percentage of fluctuation of the output voltage. If the voltage from the eliminator fluctuates to an appreciable degree,

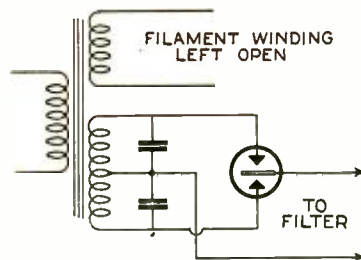

Connections to be used in the Constant Voltage "B" Eliminator when using a full wave gaseous conduction rectifier tube.

the utility of that eliminator is very limited. In the first place, the voltage fluctuations will cause very detrimental effects when the eliminator unit is used in conjunction with certain types of audio amplifiers. Low

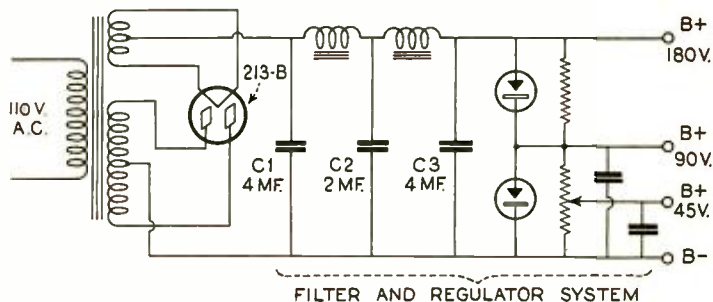

Circuit diagram of the Constant Voltage "B" Eliminator. Two voltage regulator tubes are used at the output of the filter.

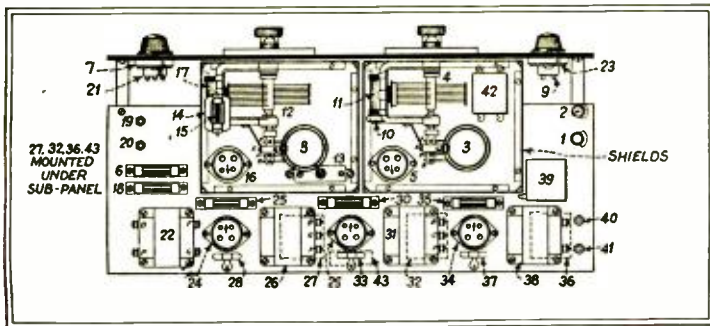

Layout of parts for the "Intertrol Five." The tip jacks 19 and 20 allow an electrical pickup to be plugged in so that the A.F. amplifier may be used for the reproduction of phonograph music

excess of that necessary for the purchase of a "B" battery to be used as a source of grid bias. Furthermore the A.C. component remaining in the output is, in the case of "C" elimination fed directly into the grid of the output tubes, with the result that this hum is amplified.

In the effort to maintain the output voltages, constant care was exercised in the selection of the power resistances. These are wire wound units possessing nil temperature coefficients.

**LIST OF PARTS REQUIRED**

- 1—Samson power transformer, 220 volt output.
- 1—Samson unit (tuned-brute force).
- 3—Ameco sockets.
- 2—Glow tubes, U.X. 874.
- 1—U.X. 213 rectifying tube.
- 2—Aerovox 4 mfd., 400 volt filter condensers.
- 1—Aerovox 2 mfd., 400 volt filter condenser.
- 2—Aerovox 1 mfd., 400 volt filter condensers.
- 1—Electrad 10,000 ohm continuously variable power resistance.
- 1—Aerovox 1,500 ohm fixed wire power resistance.
- 4—Eby binding posts marked —; 45; 90 and 180.
- 2—Boxes of Acme Celatsite hookup wire.
- 1—Westinghouse Micarta panel, 10" x 12".
- 1—Baseboard, 10" x 11".
- 1—Cutler-Hammer Toggle switch.

**The "Intertrol Five"**

The "Intertrol Five," designed by H. G. Cisin, M. E., has ample selectivity, plenty of volume and excellent tone quality.

There is one stage of tuned radio frequency amplification, a regenerative detector of special design, one stage of transformer coupled audio frequency amplification and two stages of step-up impedance coupled audio frequency amplification. Both the antenna coupler and the interstage r. f. transformer are of special construction. In these coils, the coupling between the primary and the secondary is automatically varied by the rotation of the associated tuning condenser. At short wave lengths, where the energy transfer would ordinarily be much greater, (with consequent lessened selectivity) than at long wave lengths, the coupling between the primary and the secondary of each coil is automatically made less close—and vice versa for longer wave lengths. In this way, a constant transfer of

energy and constant selectivity are kept up.

The regenerative detector provides a novel and important feature of this circuit. An inspection of the schematic diagram will show that the plate of the detector tube (16), in addition to being connected to the primary of the A. F. transformer, is also connected back through the adjustable condenser (13) to point "P," which is one end of

**RADIO ENGINEERING AP-POINTS SECOND ASSOCIATE EDITOR**

Radio Engineering is pleased to announce the appointment of Harry G. Cisin as its second Associate Editor.

Mr. Cisin is a graduate M.E. of Cornell University and also holds a certificate of Electrical Engineering. He taught Electrical Engineering at Johns Hopkins University, and in later years at Stevens Institute of Technology, under Prof. Hazeltine of Neutrodyne fame.

Mr. Cisin was at one time Engineering Editor of the Electrical Record and Technical Editor of Radio Listeners Guide and Call Book.

Several works on Marine and Electrical Engineering under Mr. Cisin's name are used as text books in a number of Schools and Colleges.

the primary of the auto-couple coil (8). In this way, regeneration is obtained, since the portion of the primary, B-P, acts as a tickler coil. Since the coupling between the primary and the secondary of this coil is varied as the condenser (12) is rotated, there is an automatic oscillation control. Consequently, regeneration is always

attained at a point of highest efficiency and with a high degree of radio frequency amplification, but on the other hand, there is a complete absence of squeals or howls. In order to get still finer adjustment of regeneration, a variable resistance is provided, as shown at (7) on the diagram. Shielding between r. f. and detector stages adds still further to the efficiency.

On the audio side, the combination of the A. F. transformer with the two impedances results in an amplifier which reproduces all audio frequencies equally well.

Electrical reproduction of phonograph music, through the "Intertrol Five" audio amplifier, may be had by plugging the terminals of the electric phonograph pickup into the tip jacks 19 and 20 and throwing switch 21 to the right.

**LIST OF PARTS REQUIRED**

- 2—Mar-Co vernier dials, type 192.
- 2—.00035 mfd. Hammarlund "Mid-Line" variable condensers (4, 12).
- 2—Auto-couple coils, Hammarlund (3, 8).
- 2—Aluminum shields, 6" x 7" x 6", Hammarlund.
- 4—Amperites, No. 1-A, with mountings (6, 18, 25, 30).
- 1—Amperite, No. 112, with mounting (35).
- 5—Eby sockets, new style (5, 16, 24, 29, 34).
- 2—Samson R. F. chokes, No. 85 (11, 17).
- 1—Thorlarsen transformer, type R-200 (22).
- 2—Thorlarsen autotransformers (26, 31).
- 1—Thorlarsen 30 henry choke, R-196 (38).
- 1—Royalty variable resistance, Electrad type "G" (7).
- 1—Electrad Tonatrol (23).
- 1—.00025 mfd. Sangamo by-pass grid condenser with clips (14).
- 1—3 meg. Durham metallized resistor grid leak (15).
- 1—.001 mfd. Sangamo by-pass condenser (10).
- 3—Acme "Parvot" 1/2 mfd., series "A" cubical condensers (27, 32, 36).
- 1—Acme "Parvot" 1 mfd., series "A" cubical condenser (42).
- 1—Acme "Parvot" 2 mfd., series "A" cubical condenser (39).
- 1—X-L variocoupler, type G-10 (13).
- 2—X-L push-posts (1, 2).
- 1—Carter "Imp" filament switch (9).
- 1—Carter, single-throw double-throw switch (long-short aerial type) (21).
- 1—.5 meg. Durham metallized resistor (28).
- 1—.025 meg. Durham metallized resistor (33).
- 1—.01 meg. Durham metallized resistor (37).
- 3—Durham vertical resistor mountings, single type (28, 33, 37).
- 4—Yaxley "Pop" jacks (19, 20, 40, 41).
- 1—Yaxley 7-strand cable complete with connector plug and mounting plate (43).
- 1—Koll Acme Celatsite wire.
- 1—Can Kester Radio Solder (Rosin Core).
- 1—Panel, 7" x 21" x 3/16" Westinghouse Micarta.
- 1—Sub-panel, 7" x 21" x 3/16" Westinghouse Micarta.
- 1—"Ivyline" cabinet, 7" x 21" x 10".
- 1—"CeCo" special detector, type "H" (16).
- 2—"CeCo" vacuum tubes, type "A" (5, 24).
- 1—"CeCo" high Mu tube, type "G" (29).
- 1—"CeCo" output tube, type "J-71" (34).

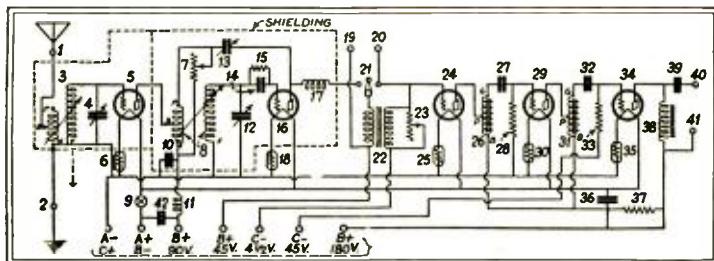

The schematic diagram of the "Intertrol Five." A novel form of regeneration control is employed in the detector circuit.



# NEWS OF THE INDUSTRY

## Conference on Engineering Materials, Berlin, 1927

The preparations for the Conference on Engineering Materials which is to take place from Oct. 22nd until Nov. 13th have already far advanced. The program of papers contains about 200 lectures to be read by scientists and practical engineers.

Three groups of engineering materials will be dealt with, namely: Iron and Steel, Non-ferrous Metals and Electrical Insulation Materials.

More than 200 testing machines, which will be shown in operation will introduce the visitors into the latest methods of testing, which are not familiar even to many engineers.

## P. C. Dittman Made President of LaSalle Radio Corp.

The directors of the LaSalle Radio Corp., of Chicago, manufacturers of LaSalle High Vacuum Radio Tubes, announce the election of Mr. Paul C. Dittman as president of the corporation.

For more than twenty years Mr. Dittman has been prominently engaged in the lamp industry—an industry which closely parallels radio tube manufacturing.

## New Algonquin Vice-President

Mr. H. R. Fletcher, for some time Director of Sales of the Algonquin Electric Company, 245 Fifth Avenue, New York, has recently been made a vice-president and director of that organization.

Before identifying himself with the Algonquin Electric Company, now some ten months ago, Mr. Fletcher was connected with the Apco Manufacturing Company as Sales Director. Previous to entering the radio industry, Mr. Fletcher was connected for eighteen years with the automobile industry. He was first a distributor of Hudson cars and Stewart Trucks, later an officer and sales manager of the Stewart Motor Corporation of Buffalo, resigning to become vice-president and manager of C. T. Silver Motor Company, eastern distributor of Overland and Willys-Knight cars, and was also general manager of the Stutz Motor Company.

## Sterchi to Concentrate on Freed-Eisemann

Sterchi Bros. have just become distributors in East Tennessee and

dealers in Knoxville for the Freed-Eisemann line of radio sets, and the firm is discontinuing the other five lines previously carried.

Sterchi's will also handle the Freed-Eisemann radio speakers, R. C. A. tubes, Basco "A" and "B" power units and other necessary equipment.

Equipment of other standard lines which are being discontinued is being sold out.

## Grebe Takes R. C. A. License

After negotiations which have extended over a considerable period of time, A. H. Grebe & Company has finally concluded an agreement with the Radio Corporation of America, whereby it becomes a licensee of the latter company.

## Sarvas Gets Westinghouse License

The Sarvas Electric Company, New York, has been appointed a licensee of the Westinghouse Electric Manufacturing Company under the "Rectox" patents. The new Tritox trickle charger made and sold under this agreement as a Sarvas-Westinghouse product by Sarvas Electric Company employs the dry-rectifier developed by Westinghouse.

## Speaker Manufacturers Merge

Announcement is made that the Radio Foundation, Inc., of New York, manufacturers of R. F. I. Speakers, and the Spartan Electric Corporation of New Jersey, for many years manufacturers of Spartan Speakers, have merged their interests and henceforth will market their products under the name of R. F. I. Speakers.

The new company, which will operate under the name of Radio Foundation, Inc., has established executive and sales offices at 116 to 118 West 14th Street, New York City, and all manufacturing will be done in the former plant of the Spartan Electric Corporation, located at 164 Pennington Street, Newark, N. J.

## Atwater Kent Company Granted Patents on Stabilized and One-Dial Receiving Sets

The United States Patent Office has just issued patents numbered 1,639,414 and 1,639,042 covering the Atwater Kent one-dial receiving sets. These

patents, in conjunction with a license under Hogan Patent No. 1,014,002, cover the one-dial construction put out by the Atwater Kent Company.

## Victoreen Radio Company Take Over New Quarters

The Victoreen Radio Company and the George W. Walker Company, have moved to their new location 2525 Chester Avenue, Cleveland, Ohio.

## Federal Radio Corporation Takes R C A License

By recent arrangement the Federal Radio Corporation has been licensed by the Radio Corporation of America under all of its patents and rights pertaining to tuned radio frequency receivers, regenerative receivers, and power supply units.

## NEMA Suggests Colored Vacuum Tube Sockets

A suggested standard for future design covering the color of vacuum tube sockets has been adopted by the Radio Division of the National Electrical Manufacturers Association. The suggested standard reads: "The colors for vacuum tube sockets in receiving sets shall be as follows: For general purpose tubes—dark red; for special detector tubes—green; for audio power tubes—orange." This suggested standard to govern future design and enable rapid identification of sockets in all sets was adopted in July, 1927.

## Zenith Sales Manager Becomes Cleveland Jobber

The resignation of N. A. Fegen as secretary and sales manager of the Zenith Radio Corporation has been announced by Paul B. Klugh. Mr. Fegen leaves the Zenith Radio Corporation to take up a wholesale distributorship for Zenith in northeastern Ohio, having his place of business in Cleveland.

## Mountford Appoints Metropolitan Distributor

C. E. Mountford announces the appointment of Radio Jobbers, Inc., 142 Liberty St., New York City, as exclusive Metropolitan distributors for the Mountford line.

## Day-Fan Gets R. C. A. License

Radio patents numbering nearly one hundred and fifty are held and controlled by the Radio Corporation of America and associated corporations are now available for use by the Day-Fan Electric Company. This announcement came from the latter firm after the signing of license agreements with the Radio Corporation of America, giving Day-Fan complete right to manufacture under the corporation's patents.

## E. K. Marshall Mourned

E. K. Marshall, Sales Engineer of the All-American Radio Corporation, passed away at his home after a year's illness. He was prominent in the technical world of radio and was very active in everything pertaining to the industry, where he had many friends.

## Features Radio Coach

The Wagner Hardware Company of Mansfield, Ohio, recently entertained 100 dealers and Arborphone representatives at the Mansfield-Leiland Hotel. The Arborphone Demonstration Coach, which was shown at the R. M. A. Show in Chicago, and now being taken on tour of the country, was exhibited during the meeting.

C. A. Anderson and Paul Smith explained in detail the Loftin-White circuit which is being used by Arborphone.

## Five Manufacturers Merge

Five radio manufacturers have effected a consolidation into a new company which is known as the United States Electric Corporation, the officers of which are as follows: A. G. Messick, president; C. D. Boyd, first vice-president; P. K. Romey, secretary and John Beatty, treasurer.

The manufacturers composing the new group are as follows: Apex Electric Mfg. Co., Indiana Electric Mfg. Co., Sentinel Manufacturing Company, Stagle Radio Company and the Cookrise Manufacturing Company.

## RCA Promotes E. E. Bucher

Following the promotion of Elmer E. Bucher to Assistant Vice-President, the Radio Corporation of America, in a statement by David Sarnoff, Vice-President and General Manager of that corporation, today announced the appointment of Joseph L. Ray as General Sales Manager.

"The growth in the business of the

Radio Corporation of America is responsible for the promotion of Mr. Bucher and the addition of Mr. Ray as General Sales Manager," said Mr. Sarnoff. "We are fortunate in obtaining the services of Mr. Ray, who until recently was General Supply Sales Manager of the Graybar Company, which position included supervision of all sales excepting telephone apparatus, line construction, materials and appliances. Mr. Ray has been with the Western Electric Company for twenty-three years. He was born at Carnegie, Allegheny County, Pennsylvania, in 1884. He will assume his new duties as General Sales Manager of the Radio Corporation, October fifteenth.

"Mr. Bucher successively has been Commercial Engineer, Sales Manager and General Sales Manager and his promotion is a recognition of unusual services rendered to RCA since its inception in 1919. Prior to that he occu-

of the total; Germany came next with 25.6 per cent, followed by Great Britain with 20.5 per cent and France with 13.7 per cent. Exports from Germany showed a slight decrease during 1926 as compared with the previous year.

United States exports of radio apparatus decreased 12 per cent in 1926 as compared with 1925, amounting to \$8,794,453. Export figures for the first half of this year, however, were valued at \$3,705,861, an increase of \$450,000 over the same period of 1926, indicating that the trade is reviving.

With the exception of transmitting sets and parts, United States exports of all items of radio apparatus increased in the first half of 1927 as compared with 1926. Shipments of receiving sets in the 1927 period were valued at \$1,128,625, an increase of 27 per cent; tubes were valued at \$501,206, an increase of 25 per cent; receiving set components reached a value of \$979,356, an increase of 30 per cent,

while exports of receiving set accessories had a value of \$939,195, an increase of 8 per cent. Exports of transmitting sets and parts fell from \$339,717 to \$157,578, a decline of more than 50 per cent from the 1926 figure.

The average gain of the three classes, sets, tubes, and parts, was 27 per cent. Accessories, which include loud speakers and head sets, have not kept pace, retarded probably by foreign competition, and because electrical characteristics of American products do not always suit the ideas of foreign purchasers. A large percentage of loud

speakers of European manufacture have higher impedance and resistance. Because of the higher cost of batteries the demand is for units of high resistance. Many consumers are concerned over operation economy, and manufacturers, particularly British, carry in their advertisements curves and technical data, which American firms do not.

## Yearly Increase of 52 Per Cent

Since 1920 the average yearly increase in United States radio sales has been 52 per cent. The largest gain was that of 1922 over 1921, when it was 190 per cent. That was the time of the inauguration of broadcasting abroad and of higher average prices. The statistics during that year were distorted, in so far as they affected broadcast receiving apparatus, by several large shipments of transmitting apparatus.

Radio broadcasting has passed through rapid stages of expansion abroad as it has in the United States.



The completely equipped Arborphone Radio Coach which is touring the United States. Demonstrations of Arborphone Receivers are given to Dealers and Jobbers.

pled important positions for seven years with the Marconi Company. Mr. Bucher has been continuously identified with and employed in the radio industry since 1903.

"Probably the most important assignment of the Assistant Vice-President, who now becomes an officer of the Corporation, will be contact with the various licensees under RCA patents. His promotion also carries with it increased responsibilities in connection with the major policies of the Company, in its programs for commercial expansion."

## U. S. Export Business in Radio Apparatus Reviving

Approximately \$30,000,000 worth of wireless apparatus is estimated to have entered into international trade in 1926, according to H. E. Way of the Commerce Department's Electrical Equipment Division. The United States was the largest exporter, American shipments making up 29.4 per cent

**ZAPON**  
**PYROXYLIN**  
**LACQUERS**  
**For Every**  
**Industrial**  
**Purpose**  
*The Recognized Standard Since 1884*  
**THE ZAPON COMPANY**  
**STAMFORD, CONN.**  
 NEW YORK · CHICAGO · LOS ANGELES · CLEVELAND  
 NEW HAVEN · OAKLAND · DETROIT  
 SAN FRANCISCO

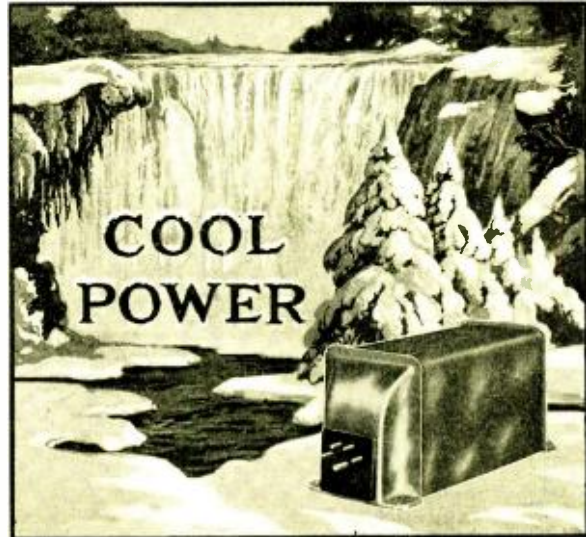

*Samson Power Block No. 210*  
 The only block which will supply 500 volts at 80 mils to two 210 tubes

## Powerize With Samson Units For Best Results

For new SAMSON Power Units insure the best there is in radio current supply by

1. Doing away with hum, motor boating and poor voltage regulation.
2. Remaining so cool after 24 hours continuous operation under full load that they will be well within the 20° rise of temperature specified by the A. I. E. E.
3. Being designed to more than meet the specifications adopted by the National Board of Fire Underwriters.
4. Insuring safety against shock because of protected input and output terminals.
5. Insuring for all tubes the correct filament voltages specified by their manufacturers.
6. Compensating for lighting circuit voltage variation by the use of a special input plug and terminal block to which is attached a 6 ft. flexible rubber-covered connecting cord and plug.
7. Being more economical in operation than other units of same power rating.
8. Living up to the name plate rating.

Limited space prevents us from listing the fourteen types that we make. Our Power Units bulletin descriptive of these is free for the asking. In addition, our construction bulletin on many different "B" Eliminators and Power Amplifiers will be sent upon receipt of 10c. in stamps to cover the mailing cost.

*Samson Electric Co.*

Main Office:  
 CANTON, MASS.

Manufacturers  
 Since 1882

Factories at Canton and Watertown, Mass.

# DeJUR

## RESISTANCE SPECIALISTS

MANUFACTURERS OF ELECTRICAL AND RADIO  
 RHEOSTATS, CONTROLLERS AND REGULATORS SINCE 1912

**ALL-METAL AIR COOLED RHEOSTAT.** Bakelite arrow pointer knob, one-hole mount. No noticeable temperature rise at constant co-efficient of conductivity.  
 Furnished any ohmage 6 to 50.

**POWER RHEOSTAT**—For Socket Power Sets. Designed for a large current carrying capacity. Large Bakelite base 2 3/4 inches in diameter. Single hole mount. Contact arm rides smoothly over surface of resistance. Soldering lugs supplied for convenient connections. Made in 2, 3, 4, 6, 10, 50, 100, 200, 400, 1,000, 2,000 ohms.

**DEJUR CONDENSERS**  
 Single—Double—Triple  
 Types in All Capacities.

**RADIO'S BIGGEST SELLING CONDENSER**  
 Moulded Bakelite insulation, condenser frame grounded to rotor, eliminates all hand capacity. Small phase angle difference; low minimum capacity.

**TO DEALERS AND JOBBERS—**  
 Write for new catalog of complete 1927-1928 Line.

**TO MANUFACTURERS—**Let us figure on your requirements. Send us specifications.

## DeJUR PRODUCTS Co.

199 LAFAYETTE STREET, NEW YORK CITY



### Dubilier Balanced Condenser Banks

Two balanced condenser banks especially designed for service with present-day power compacts, are now announced by the Dubilier Condenser Corporation of New York City.



Dubilier Condenser Bank for 210 Power Pack.

The Dubilier Condenser Bank Type PL-574 has been designed primarily for the Thordarson R-171 Power Compact, although it is equally suitable for use with the new Raytheon BH rectifier or the UX-213 or CX-313 full-wave filament rectifiers. This condenser bank, state the makers, is constructed with ample dielectric strength, so as to stand up well under the added strain of the new BH rectifier and the filament rectifiers operated at maximum capacity. There are five



Dubilier Condenser Bank for 171 Power Pack.

condensers in the bank, with a total capacity of 14 mfd. The sections are of different voltage ratings in accordance with the different voltages encountered in the various parts of the filter circuit.

The Dubilier Condenser Bank PL-575 has been designed primarily for

the Thordarson R-210 Power Compact, but the manufacturers say it is equally applicable to any other type of 216-B or 316-B high-voltage, half-wave rectifier layout for operating a UX-210 or CX-310 type of power tube, together with supplying the plate requirements of the usual receiver. This bank, also contained in a neat metal case with soldering terminals on top, contains six condensers totalling 12 mfd., and of different voltages according to the part of the filter circuit in which they are to be used.

### Benjamin Five-Prong Tube Socket

The Benjamin Electric Manufacturing Company of 120 S. Sangamon Street, Chicago, Ill., announce their new type "Y" five-prong socket for A.C. detector tubes. The heavy spring contacts are capable of carrying the heavy current required for the filament and sufficient resiliency in cushioning lessens the possibility of short-circuiting the elements of the tube which are placed very close to each other.



Benjamin A.C. Detector Tube Socket.

Special side wiping contacts assure positive tube to terminal connections. The base of the socket is black bakelite while the top is green.

### New Samson Transformers

The Samson "B" Eliminator Transformer No. 132 is rated at 40 watts. It is designed to furnish a 200-volt plate supply at 80 milliamperes or less from a "60-cycle" power source. It is fitted with windings to furnish the necessary filament supply for the UX or CX-380 tube or its equivalent, and another winding for the filament supply for one or two 171s. This transformer also can be used with Raytheon BH tubes. The no-load secondary voltage is 300 r.m.s.

A feature of this transformer, as well as of other Samson power transformers and power blocks described herewith, lies in the arrangement of the primary connection. A special terminal block is arranged so that a

plug which is furnished, together with a cord with every transformer and power block, may be inserted in a way that will fit the transformer to the line voltage existing at the location in which the transformer is used.

Samson "B" Eliminator Transformer No. 162 is designed to furnish a 500-volt plate supply to tubes such as the 210, and also lower plate voltages



Samson "B" Eliminator Type Transformer.

to other tubes from a "60-cycle" power source. It is rated at 75 watts. The No. 162 Transformer has the necessary filament supply for the rectifier tube such as the UX or CX-381. It also provides from another winding the necessary filament current for one or two 210 tubes. The effective value of the secondary voltage is 725.

The Samson A-B-C Eliminator Transformer No. 232 is designed to supply 200 volts direct current from 105-110-115-120 volt 60 cycle power source for the plate current of a receiving set, and its characteristics in this respect are identical with the Samson Transformer No. 132. It is also capable of supplying the necessary "C" voltages for the tubes that are used. It is equipped with one winding which will supply the filament current for five UX-226 or CX-326 a-c. tubes, and another winding which will supply the filament current for two UY-227 or CY-327 a-c. tubes. In addition to this winding there is another winding which will supply the filament current for two 171 tubes. This transformer is rated at 100 watts.

The Samson A-B-C Eliminator Transformer No. 262 is designed to supply 500 volts direct current from 105-110-115-120 volts, 60-cycle power source for the plate current of a receiving set, and its characteristics in this respect are identical with the Samson Transformer No. 162. It is also capable of supplying the necessary





## PRINCIPLES of RADIO COMMUNICATION

(Second Edition)

Completely Revised and Up to Date by

**JOHN H. MORECROFT**

Professor of Electrical Engineering, Columbia University  
Past President Institute of Radio Engineers

assisted by

**A. PINTO**

Electrical Engineer, Otis Elevator Co.

and

**W. A. CURRY**

Assistant Professor of Electrical Engineering, Columbia University

*Saves Hours of Calculation*

## RADIO FREQUENCY MEASUREMENTS

by

**E. B. MOULLIN, M. A., A. M. I. E. E.**

It contains formulas for measurements that the experimenter in the past had to derive for himself. Theories are made practical by examples. Practically every measurement is illustrated by an example. There are copious instructions about the manipulation of apparatus. The use of the vacuum tube voltmeter is described.

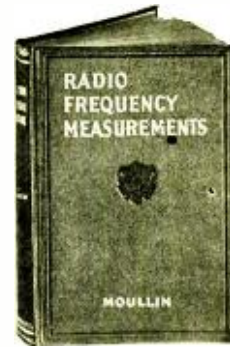

For use while measurements are in progress. This book shows how the latest discoveries in R.F. measurements are practically applied.

Practically a New Book—including all new developments but retaining the good features of the old.

# Let Radio Engineering Assist When You Are Adding to Your Technical Library

*See offer at foot of this advertisement*

### ENGINEERING WORKS

RADIO FREQUENCY MEASUREMENTS.....	by E. B. Moullin, M.A., A.M.I.E.E.	\$10.00
THERMIONIC VACUUM TUBE.....	by H. J. Van der Bijl, M.A., Ph.D.	5.00
*MANUAL OF RADIO TELEGRAPHY AND TELEPHONY.....	by Admiral S. S. Robison	5.50
EXPERIMENTAL ELECTRICAL ENGINEERING.....	by Vladimir Karapetoff	5.00
(and Manual for Electrical Testing)	Prof. EE., Cornell Univ.	
VECTOR ANALYSIS.....	by Joseph G. Coffin, B.S., Ph.D.	2.50
THEORY OF VIBRATING SYSTEMS AND SOUNDS.....	by Irving B. Crandall	5.00
	Bell Telephone Labs.	
PRINCIPLES OF RADIO COMMUNICATION.....	by Prof. J. H. Morecroft	7.50

### GENERAL PUBLICATIONS

PRINCIPLES OF MODERN RADIO RECEIVING.....	by L. Grant Hector, Ph.D.	5.00
PRACTICAL RADIO CONSTRUCTION AND REPAIRING.....	by Moyer & Wostrel	2.00
ELEMENTS OF RADIO TELEPHONY.....	by W. C. Ballard, Jr., M.E.	1.50
WIRELESS PICTURES AND TELEVISION.....	by T. Thorne Baker	2.50

\* Robison's Manual is the standard radio text book of the U. S. Navy.

*Note.—Radio Engineering will be glad to give information concerning the above works and other radio and engineering books, in which subscribers may be interested.*

*Note:* Your subscription, or the renewal or extension of your subscription saves \$1.00 toward the purchase price of any of the above publications.

Just add \$1.00 to the price listed opposite the book desired. Send check or Money Order to RADIO ENGINEERING, 52 Vanderbilt Ave., New York City, and you will receive a full year's subscription to RADIO ENGINEERING and the book (postpaid) by return mail.

"C" voltages for the tubes that are used. It is equipped with one winding which will supply the filament current for five UX-226 or CX-326 a-c. tubes, and another winding which will supply the filament current for two UY-227 or CY-327 a-c. tubes. In addition to this winding there is another winding capable of supplying filament current for two 210 tubes.

### New Philco Socket Power Units

The Philadelphia Storage Battery Company announces a number of changes and improvements in its 1928 models of Philco Socket Powers.

Two new Philco AB Socket Powers have been added for sets up to and including six tubes, using the 112 or 171 power tubes. Two additional AB units have been added for sets containing six to ten tubes, including either the 112 or the 171 power tubes. Each of the new units has relay control, which enables the user to control the A and B radio power, as well as the radio set itself, by the switch on the radio set.



Philco "A" and "B" Power Unit.

The Philco AB-656 contains the improved AA Philcotron rectifier. The AB-356 contains a dry rectifier. The manufacturers state that Philcotrons will deliver a minimum of 10,000 charging hours on low rate; 6000 on medium and 3500 on high rate and are definitely guaranteed for 3500 charging hours.

For 6- to 10-tube sets, the Philco AB-686 contains the Philcotron electrolytic AA rectifier. The AB-386 has a dry A rectifier. Both contain a UD-96 battery, of increased voltage and capacity and with more space for a solution over the plates and sediment under them.

Both these new units contain the new Philco B Socket Power, which delivers 180 volts at 60 milliamperes. Four transformer taps are provided, so that with the variable resistor, the output voltage can be adjusted to the requirements of any radio set or line voltage. Three transformer taps dispense with the lamp adjustment in the AB-656 and the AB-356. Using either of the two units with the 171 power tubes, the necessity for a power amplifier is eliminated.

The Philco B Socket Power contains no batteries, no tubes, no acids. It has no binding posts on the outside and there is no danger from high vol-

tage transmission. It is especially adapted for the UX-171 and 371 power tubes and can be operated with any make or style of battery sets from the electric current.

The Philco A Socket Power, with snap switch control, contains the new AA Philcotron. The A-603 furnishes A power for 5- and 6-tube sets. The A-36 is for 7- to 9-tube sets. The latter is relay operated and contains a dry charger. It delivers a maximum charging rate of one ampere, instead of .8 ampere maximum in the A-603—say the makers. The A-36 contains a UD-96 battery delivering extra voltage and current required to operate large sets many hours a day. Both have sockets for plugging in a B Socket Power, which is then automatically turned on and off by the same switch that controls the A Socket Power.

The new A Philcotron has been added to the 1928 Philco Trickle charger. Charge indicator balls show the user the condition of his battery at all times. It has a snap switch control and a socket for plugging in the B Socket Power and has three charging rates.

All of the Philco Socket Powers are built to conform to Underwriters' Laboratories safety specifications.

Philco announces also a larger 6-volt glass case battery, the UD-96, for the larger radio sets. This is in addition to the UD-44 and UD-86, which are being continued as heretofore. All three are of spray-proof construction and have thick plates.

### Temple Loud Speaker Comparator

Temple, Inc., of 213 So. Peoria Street, Chicago, Ill., have announced a new 5-contact switching arrangement for making loud-speaker comparisons. It consists of a bakelite turret molded in the form of a hollow truncated cone. Around the base of this cone five pin jacks are mounted which form the common leads to five speaker circuits.



Temple Loudspeaker Comparator.

Directly above each of these jacks, five more jacks are mounted in such a way as to allow the switch arm to make individual contact with the terminal of each of them.

### Aurora Tube Contact Spring

The Aurora Electric Company, 14 Dunham Place, Brooklyn, N. Y., are marketing a new contact spring for tube sockets or sub panels. The insulated eyelet, which is a part of the contact spring, has a white top and in contrast with the usual black sub-base

makes it easy to find the prong holes in the dark. The contact affords a positive pressure and wiping contact. The point of support is directly on the line of pressure when inserting the tube.

Aurora Tube Contact Spring.



The manufacturer states that this method of mounting precludes any possibility of bending or jamming the spring.

### Tritox Automatic Charger

Tritox is an automatic trickle-charger combined with relay switch and provision for plugging-in any "B"-Eliminator.

It is a Sarvas-Westinghouse product; using, as its rectifying unit, a special design of the Westinghouse "Rectox." According to the manufacturers it is free from acids, liquids, tubes or noise, and needs no attention whatever; once installed, the set-switch controls everything including battery, charger and B-supply, if used. The makers state that Tritox delivers a taper charge of from 3/4 to 1/2 ampere. The device is manufactured by Sarvas Electric Company, Inc., 37 Maiden Lane, New York.

### Etcco Keyless Drill Chuck

The Eastern Tube & Tool Company of 594 Johnson Avenue, Brooklyn, N. Y., manufacturers of the Etcco Keyless Ball Bearing Drill Chuck and Etcco High Speed Tapping Attachment, have added a new drill chuck to their line.

This new chuck as shown in the illustration is keyless, self-tightening, and has a continuous grip. It does not depend on the operator to tighten sufficiently to hold the drill. It is only necessary to close the chuck by hand. The chuck then takes its own grip after the work is started and as the drill point goes deeper the load on the chuck increases and so does the Etcco grip. If more feed is used or a hard spot is struck increasing the load on the chuck in any way, the Etcco Drill Chuck grip increases also. It is claimed no matter how tight the chuck grips, it can be released by hand by a quick twist of the wrist. Due to the construction of this chuck, there is



Etcco Keyless Drill Chuck.

# Want More Money?

## You Can Increase Your Earning Power By Learning More About Radio

If you're making a penny less than \$50 a week, you're not getting what you ought to get out of Radio.

Thoroughly-trained men—men whose knowledge of Radio is completely rounded out on every point—earn all the way up to \$250 a week.

Radio is a new industry with plenty of fine positions unfilled. There are countless opportunities in Radio for a man to earn a splendid salary. But these are not opportunities as far as you are concerned, unless you're fully qualified for them.

The only way to qualify is through knowledge—training—**Practical, complete** training, that fits you to get and to hold a better position in the Radio field.

### See If This Free Book Can Do You Any Good

I publish a 64-page book, printed in two colors and filled with facts and photos relative to Radio and its opportunities.

I don't say this book will help you, but it **does help** such a large percentage of those who read it that I can afford to send it to all who ask for it—free. You may get only a single idea out of this book that will be of any value to you. Or every line of it may give you a message.

**A message to men now in the Radio business. And another to men who would like to be in.**

*I have helped all sorts of men to advance themselves in Radio. Lots of them, men who knew absolutely nothing about Radio when they first wrote me. Some who didn't know the difference between an ampere and a battle-axe. Others, graduate electrical engineers who wanted special work in Radio. Licensed sea operators who were way behind on the "BCL stuff." "Hams" by the score. Last but not least, the service and repairman or salesman who wanted to advance or go into the Radio business on his own. And the man already in on his own, who wanted to look forward to a more solid and permanent Radio future. My free Book—see coupon below—tells about my helpful methods, and cites the experiences of a hundred men—giving photos and addresses.*

At any rate, fill in the coupon below and look it over. It costs you nothing but a two-cent stamp, and you place yourself under no obligation. I won't even send a salesman to call on you. And there's always a chance that that two-cent stamp may make quite a difference in your future.

### What My Radio Training Is

Under my practical system, a man can study at home in his spare minutes, and get a thorough, clear, practical and expert knowledge of Radio in from 4 to 12 months. The time required depends on his previous knowledge, his ability, and the time he can spare for study. He keeps right on with the job he has—no necessity for his leaving home or living on expense.

Then as soon as he's ready for a better position I'll help him to get it and to make a success of his work.

This proposition is open to anybody who is not satisfied with his job, his prospects, or his Radio knowledge. Regardless of how much you know already (or if you don't know the first thing about Radio technically) I'll fit my methods to suit your needs.

If you want to enter into any correspondence about your own situation, anything you write will come directly to me and will be held strictly confidential.

Tear the coupon off now before you turn the page, and mail it today.

**J. E. Smith, President,  
NATIONAL RADIO INSTITUTE  
Washington, D. C.**

*Oldest and Largest  
Radio Home-Study  
School in the World*

*Originators of  
Radio Home-  
study Training*

J. E. SMITH, President,  
National Radio Institute,  
Dept. K-99, Washington, D. C.

Please send me your free book about the bigger opportunities awaiting the thoroughly trained Radio man. At present I (am) (am not) in the Radio business.

Name .....

Address .....

Town ..... State .....

less slippage which reduces the wear on the drill shank and jaws. It is claimed the cost of maintenance is reduced, as there are no keys to buy.

This new chuck has been designed for use on electric and air drills and can also be used to advantage on flexible shaft units. The holding collar on the top of the chuck is held by the operator to prevent the electric or air drill from turning when opening or closing the Keyless Drill Chuck. It also eliminates certain abuses electric drills are subject to, such as, using a nail in the ventilating holes to prevent the armature from turning.

This type of Eitec Keyless Drill Chuck with holding collar is furnished with any thread or taper to fit all the standard makes of electric and air drills now on the market.

### Newcombe-Hawley Drum Speaker

Newcombe-Hawley, Incorporated, St. Charles, Illinois, have recently placed on the market a new drum speaker of distinctly different design from the conventional cone speaker of the same



Newcombe-Hawley Drum Speaker.

general exterior dimensions. The Newcombe-Hawley Drum Speaker is equipped with an exponential tone chamber or horn which provides 54 inches of tone travel and assures maximum volume and quality for a speaker of this compact type.

### S-H "A" & "B" Power Control

This unit is designed to give automatic control of any trickle charger and "B" eliminator. According to the manufacturers, with this unit in opera-



Swan-Haverstick "A" and "B" Power Control.

tion the trickle charger starts as soon as the radio set switch is turned off — and an added feature prevents the chance of a reverse current flowing back and causing the battery to run down. There are no moving parts to wear out or get out of order. Manufactured by the Swan-Haverstick Co., Inc., Trenton, New Jersey.

### Newest "Speed" Tubes

The Cable Supply Company, 31 Union Square, New York City manufacturers of a full line of "Speed"



"Speed" High-mu tube

Super Emission Radio Tubes announces the following additions to the "Speed" line.

"Speed" X 140 due to its mu of 30 achieves a high voltage amplification in resistance and impedance coupled circuits without distortion.

"Speed" X 171 is capable of passing a high plate current, even with a high negative grid bias. This means, state the makers that the high voltage signal obtained from the X 140 may be made use of and translated into a powerful speaker current without distortion.

### New Ferranti Products

Ferranti Incorporated, of New York City announce a considerable number of new audio frequency transformers and electrical instruments, which will include the following:

A super audio frequency transformer with 10 milliamperes primary, to be known as type AF-5 for special uses where best results obtainable are desired, regardless of cost. This transformer will have a ratio of 3.5-1 with exceptionally flat curve over the entire

broadcasting range and its relative efficiency at 50 cycles will be considerably over (90%) state the makers.

A new output transformer suitable for use in radio sets where the plate current in the last tube does not exceed 25 milliamperes; this transformer will be known as type OP-5, ratio 1 to 1.

A complete line of push-pull intermediate and output transformers are offered in four types; two of these will be intermediate, ratio 3.5 to 1, of the same general design as the present type AF-3 and AF-4 transformers. They will be known as types AF-3c and AF-4c respectively. One of the remaining transformers will be a push-pull output, ratio 1.4 to 1 of the same general design as the present AF-4 transformer and the fourth will be a push-pull output transformer, ratio 1.4 to 1, the same general design as the present standard output transformer which is known as the type OP-1.

A series of chokes suitable for use with "B" eliminators, to be known as types B-1, B-2 and B-3 having respective inductance of (20/40)—(6/10)—(20/48) henries.

A complete line of portable instruments for radio sets and radio measurements have been announced including flush type, projecting type and portable type, in single and multiple ranges and combinations of readings in milliamperes and volts.

It is stated that this line of instruments will have a resistance of 200 ohms per volt and will be especially suited for high class radio measurements.

A special feature is a removable fuse to protect the instrument from being burnt out if connected to a wrong scale or source of high voltage by mistake.

A further feature of the multiple range instruments will be a point switch whereby readings may be taken on any desired scale.

### Daven Electrical Pick-Up

The Daven Radio Corporation, 170 Summit Street, Newark, N. J., are



Daven Electrical Phonograph Pick-up.

also marketing an electrical pick-up for use with phonographs. This pick-up is of the electro-magnetic type and gives excellent results when feeding into a power amplifier. It is equipped with a plug which fits in the detector socket of any radio set so that the audio amplifier can be used for reproducing the music, and an enclosed volume control which can be placed in the phonograph.

# Centralab—Consistently Good

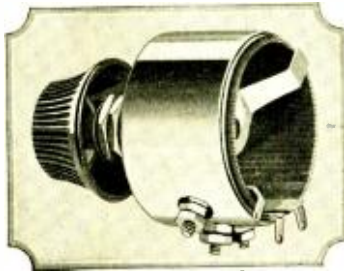

Centralab Heavy Duty Potentiometer



Centralab 4th Terminal Potentiometer

**C**ONSISTENT built-in quality, plus true statement of performance, have placed Centralab in ever-increasing favor of manufacturer and professional builder.

Accurate specifications, smooth unvariable performance, assure the users of Centralab products greater efficiency and long, trouble-free service.

There is a Centralab Resistance to fit every need in radio. Two of the latest types are pictured here. The Heavy Duty Potentiometer is a variable high resistance all wire wound with sufficient current carrying capacity to provide a true potentiometer control of "B" power voltages. The 4th Terminal Potentiometer is an ideal unit for use in power supply units as a control of output voltages. Two variable "C" bias taps can be obtained on one unit.

In addition to these, there is the Centralab Power Rheostat—a unit constructed of heat-proof materials with sufficient insulation to carry a continuous current load at a power dissipation of 35 watts or more. An ideal unit to place in primary leads as a line voltage compensator.

Other products are Centralab Radiolims, Modulators, Potentiometers and Standard Rheostats.

*Send for Folder 328. It shows the correct application of resistances in receiver and power supply circuits.*

## CENTRAL RADIO LABORATORIES

25 KEEFE AVENUE

MILWAUKEE, WISCONSIN

## TEMPLE AIR COLUMN SPEAKERS



*Improve the Tone Quality of Any Radio Set*

No matter what set you operate or sell, the Temple Speaker will greatly improve its tone reproduction. Volume and clarity that will amaze you—The sensation of every radio show in the country. Long exponential compensated air column type scientifically and acoustically correct.



*Tone chamber for manufacturers made in various sizes. Prices on request.*

**LIST PRICES**  
 No. 13—12-inch Drum type, \$29.00  
 No. 18—18-inch Drum type, \$38.50  
 No. 65—Console Cabinet type, \$57.00  
 Prices on the New Temple Unit sent on request.

**TEMPLE, INC.**  
 213 S. Peoria St., Chicago, Ill.  
**LEADERS IN SPEAKER DESIGN**

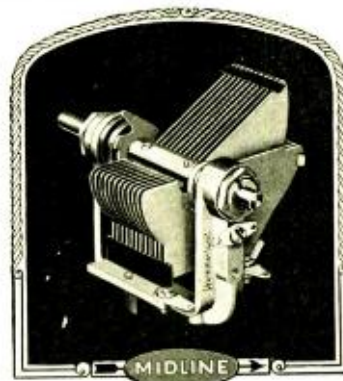

### SUPREME

Specialization has won for Hammarlund Precision Products supremacy in their field.

Built with the nationally known Hammarlund Condensers, Coils, Chokes, Shields and Drum Dials, your receiver will be nationally known. Send us your specifications.

HAMMARLUND MANUFACTURING CO.  
 424-438 W. 33rd St., New York

For Better Radio  
**Hammarlund**  
 PRECISION  
**PRODUCTS**

### New Daven Tube

The Daven Radio Corporation, 170 Summit Street, Newark, N. J., announce a new tube of the 201-A type having a five-volt filament and the



Daven 201-A Type Tube.

usual electrical characteristics. It is made in the same shape as the other Daven tubes and will fit any standard tube socket.

### The Daven Anti-Motorboater

This new Daven product has been designed to eradicate that undesirable "put-put" sound, commonly called "motor-boating," in a resistance coupled amplifier which often begins with the use of a "B" eliminator. In



The Daven Anti-Motorboater.

order to attach the unit it is only necessary to remove the middle grid leak of the audio amplifier and insert the cartridge in the clip. The unit itself may be mounted on a metal, bakelite, or wooden base-board. The makers are the Daven Radio Corporation, Newark, N. J.

### Kato "A" Eliminator

A new "A" eliminator for use on 32 volts direct current Farm Lighting Systems has been designed by the Kato Company, Mankato, Minn.

The manufacturers feature a safety protective coil which they say prevents the voltage from raising beyond the danger point.

The unit is made to supply filament current to any tubes from 1½ to 5 volts and is equipped with a voltmeter so that an accurate adjustment of the filament voltage can be made.

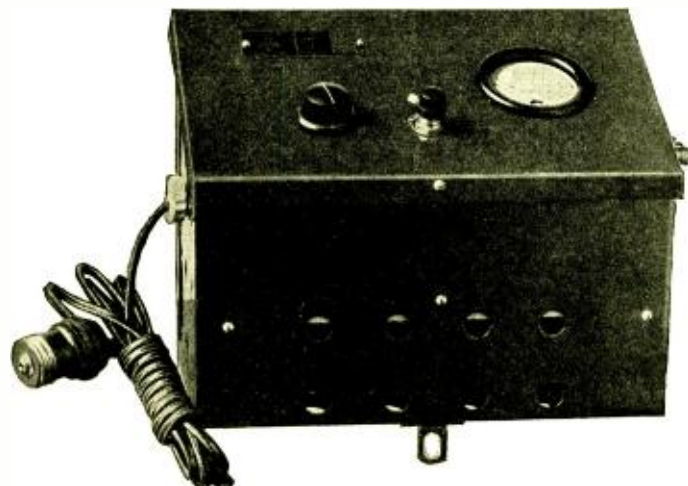

The Kato Direct Current "A" Eliminator for use on Farm Lighting Systems.

### France Dry Type Trickle Chargers

The France Mfg. Co., Cleveland, Ohio, went into production August 1st with their two new dry disc type trickle chargers. Trickle rates of ½ and ¾ ampere have been incorporated, also a booster rate of 1¼ amperes. One model is equipped with relay switch while the other is for continuous trickle charging.

### Wireless Radio Mounting Bracket

The Wireless Radio Corporation, Varick Ave. and Harrison Place, Brooklyn, N. Y., have designed a new



Wireless Radio Mounting Bracket.

brass mounting bracket for use with midget condensers, rheostats, and potentiometers. By its means these

parts may be fastened to the sub-panel or any other base. The shaft may then merely project through holes cut in the front panel facilitating its removal.

### Wireless Radio Bakelite Dial

The driving mechanism of this new Bakelite Dial is a combination friction and gear. It will work with three or four condensers. Slippage and backlash is eliminated. Provision is made so that the dial can be illuminated and equipped with a stop. Its manufacturers are the Wireless Radio Corpora-



Wireless Radio Bakelite Dial.

### Powertone Speaker Kit

The demand for cone speaker kits has reached quite extensive proportions since the outstanding features of the cone speaker are well established. Meeting this unprecedented demand the Powertone Electric Company of 221A Fulton Street, New York City, has placed on the market a power speaker kit, which when assembled operates with potentials up to 180 volts in conjunction with the types 112, 171, and 210 amplifier tubes.

tion, Varick Ave. & Harrison Place, Brooklyn, N. Y.

**AN  
INFORMATION  
SERVICE**

**for  
DEALERS  
DISTRIBUTORS  
MANUFACTURERS  
CUSTOM BUILDERS**

RADIO ENGINEERING, in addition to covering comprehensively, each month, the technical and industrial developments as they apply to the *business* of Radio Manufacturing and Distributing, offers also a valuable information service to its subscribers.

A production manager wishes to learn about sources of supply.

A designer wishes some specialized information to help him meet a problem.

A dealer wishes technical information to help him in his selection of lines.

A professional set builder wants dope about a new circuit or system.

RADIO ENGINEERING usually has this information available at a moment's notice. If not, the information is obtained from the proper source and passed on to the person interested.

*Subscribers are invited to avail themselves of this service.*

**TAKE  
ADVANTAGE  
OF THE  
NEW  
TWO YEAR  
SUBSCRIPTION  
RATE of  
\$3.00**

***If you don't get the magazine regularly the coupon below is for your convenience***

**RADIO ENGINEERING, 32 Vanderbilt Ave., N. Y. City.**

Enclosed find { \$2.00 } for which { renew } my subscription for { 1 yr. } to RADIO ENGINEERING beginning with the next issue. { 3.00 } { enter }

Name .....  
Address .....  
Town and State.....

- I am a
- Dealer.
- Distributor.
- Manufacturer.
- Prof. Set Builder.

- I am employed by a
- Dealer.
- Distributor.
- Manufacturer.
- As..... position.

**New!**

# Super Hilodyne

Entirely new circuit employing vario-frequency method of static reduction. Unrivalled distance getter. Tremendous power. Unheard of selectivity with unequalled tone quality and faithful reproduction with real single control operation.

**Watch for our page advertisement next month.**

Immune from patent infringements. Write for information regarding sets and kits.

**Algonquin Electric Co., Inc.**  
245 Fifth Avenue, New York City

## PHOTO-ELECTRIC CELLS THE BURT CELL

Without Fatigue—Highly Sensitive  
Absolutely Reproducible—Instantaneous in Response

The BURT-CELL is made by a new method and should not be confused with any other photo-electric cell. By a special process of electrolysis, the photo-electric metal is introduced into a highly evacuated bulb directly through the glass wall of the bulb, giving photo-electric material of absolute purity. The superiority of the BURT-CELL is due to these features, making possible results never before obtainable.

We also manufacture the STABILIZED OSCILLOSCOPE—the only VISUAL OSCILLOGRAPH having a linear time axis and no inertia—giving an accurate picture of high frequency wave forms.

Write for Bulletin 273

**DR. ROBERT C. BURT**  
Manufacturing and Consulting Physicist  
327 S. Michigan Ave., Pasadena, Calif.



## Audio Frequency Transformers

A new standard in audio frequency amplification! Tone quality—volume—everything a transformer should give—in the utmost degree with Ferranti.

A.F. 3.....	\$12.00
A.F. 4.....	8.50
O.P. 1.....	10.00



**Ferranti, Inc.**  
130 W. 42nd St.  
New York, N. Y.



## AN ENTIRELY NEW AND UNIQUE HEAVY-DUTY BETTER-B

**Supplies** | **A Strictly Heavy-Duty Power Unit**

Detector voltages, 22 to 45, adjustable;  
R. F. voltages from 50 to 75;  
A. F. voltages from 90 to 135;  
Power tube voltage 180 fixed.

**An Exclusive Feature**  
Tubes and by-pass condensers are protected against excessive and harmful voltages.

Output rating is 70 mils at 180 volts. Uses R. C. A. CX-280 or Cunningham CX-380 Electron. Licensed under patents of Radio Corporation of America and Associated Companies.

For 110-120 Volts, 50-60 cycles A. C. List price with cord, switch and plug, \$40. Rectifier tube \$5.

Designed for lasting service with liberal factors of safety.

Write National Co., Inc., W. A. Reedy, Pres. Malden, Mass., for new Bulletin E-124.

**NATIONAL-L-B**  
Type 7180

**A "B" That's Built for Service**  
See our Exhibit, Booth No. 8, Chicago Show, Oct. 10th-18th

## ! ATTENTION ! SERVICE STATIONS

The Lynch Improved Aristocrat enables you to build better, quicker and more economically. A complete five tube set assembled around the Lynch Deck requires an outlay of less than \$35.00 List.

The deck includes sockets, coupling condensers, resistors all mounted on sub panel—everything except the tuning units and panel—for a five tube set.

Aristocrat Deck Complete \$12.50. Custom Builders should investigate this opportunity of increasing profits on a smaller investment. Write now.



**"RESISTANCE — The Control Valve of Radio"**

A new book just off the press giving advanced information on resistor uses in Eliminators, Receiver Circuits and Amplifiers.

Price 25c

**ARTHUR H. LYNCH, Inc.**  
General Motors Bldg., 1775 Broadway at 57th St.,  
New York, N. Y.



## As Accurate As Plus or Minus 1%

The radio engineer, after all, has only gauge for selecting the resistors his comp uses. Simply stated, it is:

"How accurate is the resistor, and how long will it maintain that accuracy under average load conditions?"

Harfield Resistors can be supplied to you as accurate as plus or minus 1%. Moreover, they are absolutely guaranteed to maintain that accuracy under average load conditions.

Tell us about the resistor you want, and let us send you a sample made to your specifications. Write Hardwick, Field, Inc., 215 Emmet St., Newark, N. J., builders of

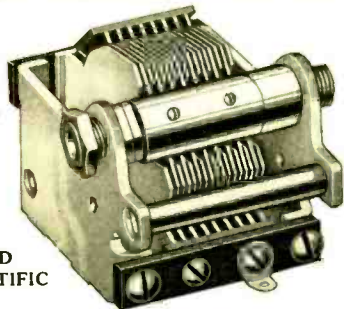

UNITED SCIENTIFIC

TYPE UXB



### JOBBERS and DEALERS

Can make money stocking this universal precision instrument, which is adaptable to any circuit. It can be mounted for all sorts of drives and ganged in any number.

- Characteristics:
1. Patent leveled brass rotor stator.
  2. Precision spacing that assures accurate calibration.
  3. Removable shaft can be adjusted to any desired length. Adaptable to ganging in any number.
  4. Universal mounting permits clockwise or counter clockwise rotation. Provided with integral frame lugs for sub-panel mounting.
  5. Modified straight-line frequency curve to take care of present day broadcasting wavebands.

This new condenser is made in .00035 and .0005 sizes. The extremely low price of this quality instrument is another reason why you should handle it.

Make further inquiries TODAY.

### United Scientific Laboratories, Inc.

80-82 Fourth Ave.,

New York City

BRANCH OFFICES

St. Louis  
Chicago  
Boston  
Minneapolis

Canadian Offices.



BRANCH OFFICES

Cincinnati  
Los Angeles  
Philadelphia  
San Francisco  
London, Ontario



# Radio Set Analyzer

A Quality Product



Pattern No. 133 Radio Set Analyzer

The Jewell Pattern No. 133 Radio Set Analyzer was designed to assist radio service men in reducing time on service calls, giving them an instant check on set conditions. It will be found particularly adaptable to service calls of a contract nature, requiring monthly inspection of sets.

In operation it is very simple. With the plug of the analyzer in place in the socket of a radio set and the tube in the socket of the analyzer, complete characteristics of that stage can be obtained. "A", "B" and "C" voltages, plate current and grid bias are instantly obtained by pressing the proper push button. In addition, a grid shift push button is furnished and gives a direct indication of tube conditions. There are no complicated switches to get out of order. Pressing the wrong push button does no damage. In fact, they can all be pressed at one time without injury.

The instrument is a high grade voltmeter having a voltmeter resistance of 1000 ohms per volt and ranges of 0-8, 80 and 200 volts and 0-20 milliamperes. Separate binding posts allow for external connection to the instrument for individual circuit tests.

The case is covered with genuine Morocco leather and is 4½ x 6½ x 8½ inches.

Write for descriptive circular No. 1115.

### Jewell Electrical Instrument Co.

1650 Walnut Street - - - Chicago

"27 Years Making Good Instruments"

# Vacuum Tube Directory

Name	Type	Use	"A" voltage		Fil. current (Amps.)	Voltages (minimum)		Voltages (maximum)		Voltage B Det.	Grid return (Det.)	Plate current (milliamps)		Output resistance (Ohms)	Mutual conductance (Micromhos)	Voltage amplification factor	Remarks
			Bat.	Fil.		"B"	"C"	"B"	"C"			Min.	Max.				
Aecturus Radio Co.	26	A. C. Detector		15	0.35	22	4.5	45	9	45				9500	1100	10.5	Positive "C" voltage
	28	A. C. Amplifier		15	0.35	45		90	1.5					9500	1100	10.5	R. F. and A. F. amplifier
	30	A. C. Power Tube		15	0.35	135		180	22.5					2700	1650	4.5	
Armstrong Electric Co. (Armour)	C. F. 112	Power Amplifier	6	5	0.5	90		157			F+			4500-8000	1200-1700	7.5-8.0	
	C. F. 571	Power Amplifier	6	5	0.5	90		180						2500	1200-1700	3.0-3.5	Use output device above 135 v. "B"
	C. F. 510	Power Amplifier	8	7.5	1.0	180		450						3000-5000	1100-2500	7.0-8.0	Use output device
	C. F. 516 B	Half Wave Rectifier	8	7.5	1.0												85 M. A. output
	A. C. 100	A. C. Tube	1.0	1.0	2.5	22		157						6000-12000	800-1400	7.5-8.0	Step-down trans. for fil. supply
C. E. Manufacturing Co.	K	R. F. Amplifier	6	5	0.25	45	0.0	135	3.0	45-90	F+	3.0	4.8	11000-12800	975-1130	12.5	May be used as detector
	G.	Hi-Mu	6	5	0.25	90	0.5	180	5.0	67-90	F+	0.8		25000-	800-	20	Det., Res. Impedance Amplifier
	II	Special Det.	6	5	0.25	67	3.0	90	4.5	67-90	F+	1.2	3.0	14000-15900	910-1030	14.4	Detector only
	F	Power Amplifier	6	5	0.5	90	6	180	15	45	F+		5	5300	1500	8	
	J-71	Power Amplifier	6	5	0.5	90	16.0	180	45.0			9.0		2500-	1200-	3.0	Use output device above 135 v. "B"
	L-10	Power Amplifier	8	7.5	1.25	250		425	20					4500			Use output device
	AX	General Purpose	6	5	0.25	90	4.5	135	7.5	45	F+		3	10500	810	8.5	
	M-26	A. C. Amplifier		1.5	1.05	90	4.5	135	9								R. F. and A. F. Amplifier
	N-27	A. C. Detector		2.5	1.75	90	4.5	135	9	45							
	D-G	Full-wave Rectifier	85 milliamperes at 300 volts														Gaseous conduction type
	R-50	Full-wave Rectifier	6	5	2.0												
R-81	Full-wave Rectifier		7.5	1.25													110 M. A. at 750 v.
Eureka T. & M. Co.			Full-wave Rectifier, 125 milliamperes output														
Q. R. S. Music Co.	201-A	General purpose	6	5	0.25	20		180						8000	1000	8	
	200-A	Special Detector	6	5	0.25			45		45				5000		7.5	
	112	Power Amplifier	6	5	.5	135		180								3	
	171	Power Amplifier	6	5	.5	135		180						2500			Use output device above 135 v. "B"
		Full-wave Rectifier	60 milliamperes at 150 volts														Gaseous conduction type
		Full-wave Rectifier	85 milliamperes at 200 volts														Gaseous conduction type
		Full-wave Rectifier	100 milliamperes at 350 volts														Gaseous conduction type
		Full-wave Rectifier	100 milliamperes at 500 volts														Gaseous conduction type
		Full-wave Rectifier	400 milliamperes — for "B" and "C" elimination														Gaseous conduction type
		Glow tube	Voltage regulator tube														



*Announcing*  
**ARCTURUS  
A. C. TUBES**

DETECTOR—AMPLIFIER—POWER

*Now — to the convenience and economy of  
A. C. operation is added unfailing quality  
reception with the reliable Arcturus A. C.  
Tubes.*

All Arcturus tubes are of the heater type, employing a negative temperature co-efficient heater that eliminates disastrous current surges. Unique features make possible unfailing reception of unusual tone quality throughout a life well in excess of 1000 hours.

All leads, heater and elements, are brought down to a standard four prong base. Less changes need be made in adapting D. C. receivers to Arcturus operation than to any other A. C. Tubes.

We have prepared engineering and servicing data on these tubes which we shall be pleased to send on request.

**ARCTURUS RADIO COMPANY**  
INCORPORATED  
255 Sherman Avenue, Newark, N. J.

## Radio Engineering

# VACUUM TUBE DIRECTORY

The vacuum tube directory will be a permanent feature in each issue of RADIO ENGINEERING for the next few months. It has been inaugurated in response to a demand set up by readers who continually write to RADIO ENGINEERING regarding the characteristics of tubes, their uses and particular applications.

It is in no sense a recommendation of one make of tube over another. It merely places before the readers a permanent up-to-date reference which will anticipate many questions and, we hope, save both time and trouble for them.

It is, of course, impossible to list *all* makes and *all* types. Subscribers are invited to write to the Readers' Service Bureau, as they have in the past, if any additional information is needed. RADIO ENGINEERING has available a mass of data covering different tube types which it is absolutely impossible to print due to lack of space.

Tube manufacturers are requested to inform us immediately of the characteristics of any new tubes or of changes made in the characteristics of present types.

U. S. DEPARTMENT OF COMMERCE, BUREAU OF STANDARDS

Platinum Filament  
Radio Tubes

# ARMOR

*"A Tube For Every Need"*

Selectivity  
**SUPERIOR**  
Volume

Quality

Desirable jobbing territories still open.

Armstrong Elec. & Mfg. Co., Inc., Newark, N. J.

**KELVIN TUBES** FULLWAVE NO FILAMENT RECTIFYING  
**ARE DIFFERENT**



Longer life  
Larger output  
Quieter operation  
Quicker pickup

125 M. A. Price \$4.00

Uniform quality  
Sole Distributors  
**Eureka T & M Co.,**  
42 Walnut St., Newark, N. J.  
Guaranteed for one year

Tipless Construction

**Independent Laboratories**  
Newark, N. J.

# GETTER

Oxide Coated Filament  
Special Glass Apparatus

*Cerium Alloys*

Exclusive Sales Representative  
**A. U. HOWARD**  
50 East 42nd St. New York City  
Phone: Murray Hill 0342 & 0343

Your "B" Battery Eliminator  
will give you better service

with

# Q·R·S

Trade Mark Registered

## Gaseous Rectifier Tubes

**ARE BETTER**

60 Milliamperes - \$4.50  
85 Milliamperes - 4.50  
400 Milliamperes - 7.00



Ask for Catalog of full line of Standard Tubes.

### Guaranteed

The standing of the Q. R. S. Company, manufacturers of quality merchandise for over a quarter of a century, establishes your safety.

Orders placed by the leading Eliminator Manufacturers for this season's delivery, approximating Four Million Dollars' worth of Q.R.S. Rectifier Tubes, establishes the approval of Radio Engineers.

*Ask any good dealer.*

## The Q·R·S Company

MUSIC

**Manufacturers**

Executive Offices:  
306 S. Wabash Ave., Chicago

Factories: Chicago—New York—San Francisco—Toronto,  
Canada—Sydney, Australia—Utrecht, Holland

Established 1900  
References—Dun, Bradstreet, or any bank anywhere

## PROFESSIONAL DIRECTORY

For Blueprints, Additional Data and Information on

### INTERTROL FIVE

Reviewed in this Publication

Send \$1.00 to

**ALLIED ENGINEERING INSTITUTE**  
250 West 57th St., New York City

*Radio Engineers and Designers*

*Custom Work a Specialty*

**H. & F. RADIO LABORATORIES, Inc.**  
*Radio Engineers*

168 Washington St.  
New York City

Consulting "SUPER-HETERODYNE" Experts

### PROFESSIONAL SET BUILDERS

You can make more money by using DAR-MAC Precision Products in the custom-built sets you build for your clients. Write today for full information.

**DAR-MAC LABORATORIES**  
19 So. Wells St., Chicago

*Radio Engineering and Engineering Advertising*

### ZEH BOUCK

*Laboratory*

502 West 143rd St., New York City  
Tel. Edscombe 9513

*Federated*

### RADIO TRADE SCHOOL

*General Instruction on Service and Set Building*

Write for Catalog

**RADIO TRADE ASSOCIATION OF MICHIGAN**  
4464 Cass Ave. Detroit, Mich.

### AUSTIN C. LESCARBOURA

*Technical Publicity for Manufacturers*

*Laboratory*

*Office*

Croton-on-Hudson, New York  
Tel. Croton 390

Tribune Bldg.  
New York City, N. Y.

## TESTING OF RADIO APPARATUS

Condensers calibrated at Radio Frequencies.  
Station Wave Lengths measured and checked—Tube Characteristics determined.  
Wave Meters, Standard Capacities and Inductances calibrated.

### ELECTRICAL TESTING LABORATORIES

80th St. at East End Avenue

New York City, N. Y.



### The New Improved Hi-Q\* Six

(Write for Full Particulars)

Every professional radio man and service station who is interested in making more money out of radio should get the full facts about the 1928 Hi-Q Six Receiver—designed by ten of America's leading manufacturers—using the finest parts in America—incorporating every modern constructional feature—backed by the biggest "CUSTOM-BUILT" advertising campaign of its kind in the industry. Hammarlund-Roberts Receivers have always been accepted as the finest at their price. For 1928 the Hi-Q Six is recognized as the finest receiver available—regardless of price. Send 25 cents for 48-page Construction Manual and full particulars.

Hammarlund-Roberts, Inc., 1182-G Broadway, N.Y.C.

**Hammarlund**  
**ROBERTS**  
**—Hi-Q SIX—**

*Associate Manufacturers.*

Samson Elec. Co. Hammarlund Mfg. Co. International Resistance  
Carter Radio Co. Benjamin El. Mfg. Co. Co. (Durham Resistors)  
Sankamo El. Co. Acme Wire Co. (Parvot) Itallall Co. (Amperite)  
Yaxley Mfg. Co. H. H. Eby Mfg. Co. Westinghouse Mfg. Co.

## *Ensco*

**THE ORIGINAL AND WORLD'S  
FINEST 3 FOOT SPEAKERKIT**

**STANDARD  
KIT**  
**\$10.00**

**WALL KIT**  
with hardwood  
frame  
**\$11.00**

Sell the Ensco 3-foot and 2-foot Kits—the original, best and most favorably known. Backed by a large and consistent national advertising. Accorded by far more publicity than any other speaker kit. Complete line of roll, wall, console and pedestal models ranging in price from \$10 to \$17.50. Slightly higher in Canada.



### SPECIAL DEALER'S PROPOSITION

To dealers and professional set builders we have a most interesting story—and a most attractive selling proposition. Write on your letterhead to the nearest office listed below for our booklet, prices, discounts, etc.

### ENGINEERS' SERVICE COMPANY

25 Church St., New York  
73 Cornhill, Boston

28 E. Jackson Blvd., Chicago  
331 Bay St., Toronto, Canada

# WHAT'S NEW?

RADIO ENGINEERING asks manufacturers to send in monthly information about their new products, campaigns, changes in personnel, circuits, etc. At the same time the technical staff would like literature for the use of the Readers' Service and Information Bureau. Many already are sending RADIO ENGINEERING systematized monthly data. We want more—

Let "NEWS OF THE INDUSTRY" and "NEW DEVELOPMENTS OF THE MONTH"

*Grow with You.*

STATEMENT OF THE OWNERSHIP, MANAGEMENT, CIRCULATION, ETC., REQUIRED BY THE ACT OF CONGRESS OF AUGUST 24, 1912, OF RADIO ENGINEERING.

Published monthly at Albany, N. Y., for October 1, 1927.

State of New York }  
County of New York } ss.

Before me, a Notary Public in and for the State and county aforesaid, personally appeared B. S. Davis, who, having been duly sworn according to law, deposes and says that he is the Business Manager of RADIO ENGINEERING, and that the following is, to the best of his knowledge and belief, a true statement of the ownership, management, etc., of the aforesaid publication for the date shown in the above caption, required by the Act of August 24th, 1912, embodied in section 411, Postal Laws and Regulations, to wit: 1. That the names and addresses of the publisher, editor, managing editor, and business managers are: Publisher, Radio Engineering Magazine, Inc., 52 Vanderbilt Avenue, New York; Editor, M. L. Muhleman, Bronxville, N. Y.; managing editor, M. L. Muhleman, Bronxville, N. Y.; Business Manager, B. S. Davis, Scarsdale, N. Y. 2. That the owners are: B. S. Davis, Scarsdale, N. Y.; Roy T. Atwood, Albany, N. Y. 3. That the known bondholders, mortgagees, and other security holders owning or holding 1% or more of the total amount of bonds, mortgages, or other securities are: None. 4. That the two paragraphs next above, giving the names of the owners, stockholders, and security holders, if any, contain not only the list of stockholders and security holders as they appear upon the books of the company but also, in cases where a stockholder or security holder appears upon the books of the company as trustee or in any other fiduciary relation, the name of the person or corporation for whom such trustee is acting, is given; also that the said two paragraphs contain statements embracing affiant's full knowledge and belief as to the circumstances and conditions under which stockholders and security holders who do not appear upon the books of the company as trustees, hold stock and securities in capacity other than that of a bona fide owner; and this affiant has no reason to believe that any other person, association, or corporation has any interest direct or indirect in the said stock, bonds, or other securities than as so stated by him.

(Signed) B. S. DAVIS, Business Manager.

Sworn to and subscribed before me this 1st day of October, 1927.  
(Seal) J. A. WALKER, Notary Public.

Kings County,  
Kings Co., Clerk's No. 390.  
Kings Co., Registers No. 9100.  
New York Co., Clerk's No. 159.  
New York Co., Registers No. 9166.  
Commission expires March 30, 1929.



## Accepted as Standard

REALIZING the ever increasing public demand for radio receivers of the highest quality, the leading set manufacturers of the radio industry now specify

# Polymet Products

as standard equipment for all their models to insure that dependability and efficiency associated with a reputable name or trade mark. Among the radio set manufacturers now using Polymet radio essentials are the following

- |          |         |                |
|----------|---------|----------------|
| ERLA     | KING    | MAGNAVOX       |
| FADA     | KODEL   | MOHAWK         |
| FRESHMAN | KOLSTER | STEWART-WARNER |

### Stock Polymet Radio Essential For a Quick Turnover

Among amateurs and professional set builders, Polymet Radio Essentials are as well and favorably known as they are among radio manufacturers.

No progressive radio dealer's stock is complete therefore without a full line of Polymet products. The efficiency and dependability of Polymet parts backed by consistent national advertising in all the leading radio magazines and newspapers throughout the country, make Polymet radio essentials the quickest turning and biggest profit-making line of parts in the radio industry.

*Send for our latest catalog which includes several of the most popular power circuits*

See our exhibit at Chicago Radio Show, Booth 8 Section DD



Pure Metal Grid Leak or Resistor



Polytrols Tube Ballasts



Metallized Grid Leak or Resistor



Bakelite Molded Condenser



Filter Condenser

POLYMET MANUFACTURING CORPORATION  
599-601 Broadway New York City

# POLYMET PRODUCTS

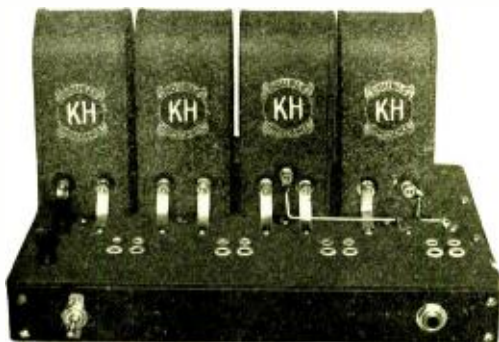

# HARKNESS

## Tuned Double Impedance Push-Pull Amplifier

ALL the latest improvements in the Hiler system of tuned double impedance audio amplification are included in this new amplifier designed by Kenneth Harkness and licensed under Hiler audio patents. The push-pull output stage eliminates the last trace of distortion. The amplifier can handle more volume and the tone quality is better than ever.

### Makes Tone Perfection a Thrilling Reality!

The reproduction of this new amplifier is more realistic than anything you have ever heard before. Speech and music are reproduced in pure, rich, natural, full-rounded tones. Every musical note, from the deepest bass to the highest treble, is heard with full volume and with all its distinctive tone-color. Never before has it been possible to re-create musical sounds with such marvelous fidelity.

### You Can Make Big Money on Sales

The Harkness amplifier will greatly improve the volume and tone quality of your set. You can attach it in a few moments, without tools, and without making any changes in your set. Then demonstrate it to your customers and you can sell them by the score—at a real profit. One of our dealers sold 15 amplifiers in two weeks—a profit of nearly \$250.00.

### Your Satisfaction Guaranteed — Order NOW!

The Harkness amplifier is unconditionally guaranteed. Mail your order today and the amplifier will be sent you by return. Attach it to your set and hear the improvement. If you are not entirely satisfied, return the amplifier and your money will be instantly refunded. Only a limited number of amplifiers are available at the special low price of \$19.50. Mail your order NOW!

Prices to Dealers and Set-Builders

Tuned Double Impedance Push-Pull Amplifier Complete, ready to operate } **\$19.50**  
List \$35.00

Tuned Double Impedance Push-Pull Amplifier Kit (1st and 2nd stage couplers, push-pull coupler and push-pull output unit) } **\$12.75**  
List—\$23.50

Pair of Push-Pull Units (Push-Pull Coupler and Output Unit) } **\$7.50**  
List—\$12.50

## K. H. Radio Laboratories, Inc.

Kenneth Harkness, Pres. & Chf. Engineer.

181 Sullivan St., New York

## POWERTONE

36-in. Giant Cone Speaker

KIT, including stand, \$12

YOU GET—1 Front Sheet (designed); 1 Back Sheet; 2 Metal Baffle Rings; 1 Mounting Bracket; 1 set Apex Fittings; 1 POWERTONE UNIT; 1 Stand; 1 Tube Cement; 1 set Screws, Nuts, etc.

### FULL INSTRUCTIONS

Can be assembled by any one in ¼ hour.

Dealers:—Ask for our attractive proposition.

POWERTONE ELECTRIC CO.  
221A Fulton St. New York City  
1 Flight Up.—Cort. 6209



ACCURATE TO

1/5 of 1%

OF THE RATED INDUCTANCE

THAT is why Precision Diamond Cut Coils are better. That is why you can use them in gang condenser sets. That is why so many radio engineers are using them today. The diamond cutting gives accurate spacing and uniform diameter to the rigid bakelite form. Which in turn assures you that the inductance will be the same year in and year out. You can drop them but you can't change their value unless you break the form. Be sure your coils are PRECISION DIAMOND CUT.

Not all our coils are as accurate as 1/5th of one per cent, but all are accurate to at least one per cent. What other coils can compare with these. Precision Coils are indeed the "Standard of Comparison."

Send for our new catalog.

PRECISION COIL CO., Inc.  
209 Centre St., New York, N. Y.

## DRESNER COILS

DRESNER space wound and threaded coils may be used with any type of .00035 MF maximum capacity condenser, whether it be single, triple or single and double factors. They are matched, machine wound and laboratory tested. The report of the testing laboratory of New York University, indicates the high electrical qualities of Dresner coils.

Their external magnetic field is the lowest. We are equipped to design and wind special coils to set manufacturers' specifications. Write for complete details and

Send for prices, samples, etc.

DRESNER RADIO MFG. CORP.  
564 Southern Boulevard, New York City



(Actual Size)  
Designed for Manufacturers' Use

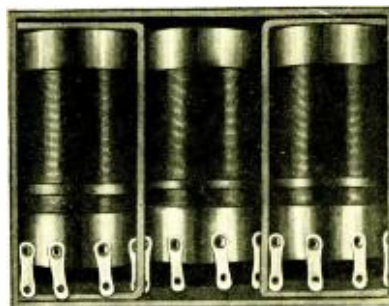

Packed in Sets of Three for Jobbers and Retailers



**A  
Message  
to  
Manufacturers—**



**A manufacturer's advertising budget suffers often from too many divisions.**

**A message to the Radio Dealer is ordinarily separate from that to the consumer.**

**An advertising campaign in RADIO NEWS reaches more dealers than any Radio Magazine or Paper published—while its consumer circulation, nearly a quarter of a million, is more than 2½ times that of any other Radio Monthly.**

**Complete coverage of the entire field can be had in every issue of RADIO NEWS.**

**At one stroke, RADIO NEWS places your products on the dealers' shelves and in the hands of the consumer and in less time than any magazine in this field.**

**RADIO NEWS can boast a circulation that is entirely devoid of waste. Every reader is actively radio conscious.**

**Further information, rates and sample copies of RADIO NEWS, will be furnished gladly, on request.**

**EXPERIMENTER PUBLISHING CO., Inc.  
230 Fifth Avenue, New York, N. Y.**

**REPRESENTATIVES**

**HARRY E. HYDE, 518 Drexel Building, Philadelphia, Pa.**

**A. J. NORRIS HILL CO., 5 Third St., San Francisco, Calif.  
412 West 6th St., Los Angeles, Calif.**

**L. F. McCLURE, 720 Cass Street, Chicago, Ill.**

**DAVIES, DILLON & KELLY, 15 West 10th St., Kansas City, Mo.  
T. F. MAGRANE, Park Square Bldg., Boston, Mass.**

# RADIO CATALOG free

**2000**  
Exceptional  
Radio  
Values

**1928**  
WHOLESALE  
CATALOG

**RADIO of**  
Sets, Kits  
and  
Everything  
in Radio

SHURE RADIO CO.  
WHOLESALE  
V.I.P. CHECK  
PRICE LIST  
AND  
DISCOUNT  
SHEET

**LOWEST**  
PRICES  
to  
DEALERS

Send Today for This Great Book

Compiled exclusively for dealers in radio sets, radio parts and for set builders. An amazing catalog containing the newest things in the world of radio.

Unbeatable values in radio parts, kits and supplies of National fame. A complete array of cabinets and consoles, in all the latest styles, finishes and popular sizes, and at unmatched prices.

We can supply complete kits for any of the circuits reviewed in this issue of "Radio Engineering."

**SHORT WAVE SECTION**—Our catalog contains a section devoted to a showing of the highest grade short wave receiving and transmitting apparatus. Also the finest electrical appliances for use in the home.

**WRITE TODAY**—Whatever your radio needs may be, you will find them in our 1928 catalog. Write for a copy today.

Shure service means sure profits. You can take orders direct from our illustrated list price catalog. The high quality of our products eliminates loss. Large stocks offer you a large selection. Our speedy shipments insure your customers' good will and bigger profits for you.

**SHURE RADIO COMPANY**  
337 K. WEST MADISON STREET, CHICAGO, ILLINOIS

**Pep Up Your Set**

Model "N"  
Vario  
Denser



**X-L PRODUCTS**

Quick and easy tuning—more volume, clearness, stability, with an X-L Vario Denser in your circuit. Specified and endorsed by foremost Radio designers in all latest and best hook-ups.

**MODEL "N"**—Micrometer adjustment easily made, assures exact oscillation control in all tuned radio frequency circuits. Neutrodyne, Roberts' tubes, Brownie-Drake, Silver's, Knockout, etc. Capacity range 1.8 of 20 Mfd. Price \$1.00

**MODEL "G"**—Obtains the proper grid capacity of Cockaday circuits filter and insensitate frequency tuning in super-heterodyne and positive grid bias in all sets. Capacity range, Model G-1 .00002 to .0001 Mfd. Model G-5 .0001 to .0705 Mfd. Model G-10 .0003 to .001 Mfd. Price each with grid clips, \$1.50.

**X-L PUSH POST**—Vibrations will not loosen, releases instantly. Price each 15c

Also in strip of 7 on black panel marked in white. Price \$1.50

**FREE**—New, up-to-date book of wiring diagrams showing use of X-L units in the new LOFTIN-WHITE constant coupled radio frequency circuit, and in other popular hook-ups. Write today.

**X-L RADIO LABORATORIES** 2423 Lincoln Ave. CHICAGO, ILL.



X-L Push Post

**Set Builders!**

Be first to build the new Magnaformer 9-B Circuit—Commander-in-Chief of the Air—featured by Radio Authority (4), M. Test in Sept. and Oct. Radio, Head his articles, See also Sept. and Oct. Popular Radio and C. R. Call Books.

Two years ahead of the field. Outstanding feature is its marvelous Tone Quality. Women, musicians and experts especially are enthusiastic in their praise of its amazing fidelity of tone. The NEW scientifically designed and precisely matched Magnaformer Intermediate Long Wave R. F. Transformers are the cause. **Everyone who hears or tunes a Magnaformer 9-B decides to own one immediately.** Beautiful in appearance. Changes from 9 to 8 or 8 to 9 tubes instantly. Great distance getter—super-selective—a world of volume—quiet operating—easy to tune—easy to build. Any one can do it. All standard parts. **NO AFTER-SERVICE!** The ideal set to build for others. **Send NOW** for free descriptive literature.

RADIART LABORATORIES COMPANY  
19 S. La Salle Street Dept. 117 Chicago

## For "Super" Builders

We have on hand a limited quantity of

# AALCO LOOPS

Formerly \$12.50 each

We are now offering them to Professional Builders at

## \$5.00 each

POSTPAID

**ASTOUNDING VALUE!**

Folds instantly to any desired shape, but requires no auxiliary adjustments.

Wires are always taut, regardless of whether loop is open or folded.

Equipped with center tap for super-heterodynes using a regenerative loop circuit.

Inductance value can be changed to make dials read alike.

---

F. D. DYSINGER  
Market Square, Albany, N. Y.

Enclosed you will find my remittance for \$5.00. Send at once, postpaid, one AALCO LOOP.

Name .....

Street .....

City ..... State .....

**N O W**

Order Your Parts for the New

## WORLD'S RECORD SUPER

The great demand for this receiver has resulted in delays for immediate shipment by the manufacturer.

HOWEVER

We have a good supply of all the parts necessary to build this marvelous set. Send in your order today and save time. Lowest prices to set Builders and Dealers. Write for circular.

**THOR RADIO CO.**  
35 So. Dearborn St., Chicago

# FREE

## TO SET BUILDERS AND DEALERS

Write today for our new 1928 Catalog. Shows the latest and best nationally advertised radio equipment. Lists all popular circuits of the year including Tyrman Ten, Magnaformer, Silver Super, Aero Seven, Daven, and numerous others. All parts in stock ready for shipment. No delays. Lowest prices given to Professional Set Builders and Dealers. Write today for this catalog.

**MILLER-WELLES CO.**

20-D West Kinzie Street Chicago, Ill.

# The biggest Edition—

The biggest edition ever published. Brimful of newest information, latest circuits and hook-ups, new revised list of world's broadcasting stations with schedules and new wave lengths in meters and kilocycles. 264 pages of news, ideas, and valuable information for fans, set builders, radio dealers and everyone interested in radio's advancement.

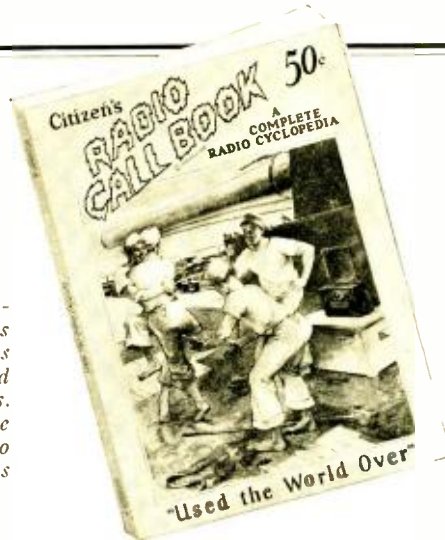

## Citizens Radio Call Book

New September, 1927 Edition

On Sale Now at Newsstands and Radio Stores

### Wonderful Rotogravure Section

One of the big features of the new Call Book is the 16-page rotogravure section. It is replete with photographs and views. Your favorite radio artists, pictures of studio life, prominent announcers and other features are shown in actual photographic views.

### Complete Details on Newest Circuits

Every Receiver Designed and Thoroughly Tested in Our Laboratories Complete constructional details on the newest modern radio circuits are given, including the Aero-7, Camfield Super-Selective-9, Remler 45 KC., Nine-in-Line, Meloheald 14, Magnaformer 9-8, Eight-in-Line, Tyrman Super 10, Infradyne, World's Record Super 10, Equamatic, Browning-Drake, St. James Upright-8 and others.

### A Complete Radio Cyclopedia

Be sure that you get the CITIZENS RADIO CALL BOOK, the original and most widely circulated publication of its kind. Accept no substitutes. Published four times yearly, September, November, January and March. On sale now at newsstands and radio stores the world over, or subscribe now and be sure of receiving each issue as published. Use the handy coupon below and mail in now.

Mail This →  
Coupon Today!

CITIZENS RADIO SERVICE BUREAU, Inc., Publishers (RE)  
 508 South Dearborn St., Chicago, Ill., Dept. R, U. S. A.

Date..... 192....

Please enter my subscription for the CITIZENS RADIO CALL BOOK for [ ] one year, \$1.75; [ ] two years, \$3.25; [ ] three years, \$4.50. Enclosed please find..... in payment for same, mailed postpaid four times yearly, January, March, September and November. Canada and Foreign, \$2.00 yearly.

Name.....

Address.....

City.....

State.....



**Make Money Selling**

# TRUVOLT

*An All-Wire Variable Voltage Control*

Cash in on the trend toward Electrified sets by selling this superior voltage control.

Special construction gives greater radiation surface, cooling on same principle as air-cooled engines.

1—Made entirely of wire; permanently accurate; lasts indefinitely. 2—Permits potentiometer control; positive contact at all times. 3—Nichrome wire resistance—very low temperature coefficient.

Eight stock types with resistances up to 50,000 ohms. All rated at 25 watts. List \$3.50 each. *Also full line of fixed wire resistances.*

Write for descriptive booklet and full information to Dept. 19B, 175 Varick Street, New York

**"This Is An Eliminator Year"**

# ELECTRAD

# ALHAMBRA

**CONE SPEAKER PAPER**

*ALHAMBRA PAPER gives ABSOLUTELY UNIFORM RESONANCE. It has no resonance point of its own. Just as*



*the cone speaker is supreme in radio reproduction, so also is ALHAMBRA supreme in imparting the utmost in tone quality.*

Just as 9 out of 10 Radio Speaker Manufacturers use ALHAMBRA exclusively—so do the vast majority of skilled professional builders insist upon ALHAMBRA only.

Cone speaker manufacturers are invited to communicate with us concerning their requirements for the coming season. ALHAMBRA is furnished in sheets suitable for cone speakers of 13 inches to 36 inches diameter—special sizes to order. Prompt shipment guaranteed.

**The SEYMOUR CO., 323 W. 16th St., New York City**

## PACKING PROBLEMS SOLVED



We can overcome your packing difficulties, whether you ship large sets or small sets—heavy power equipment or fragile speakers—whether the weight is *ten pounds or five hundred pounds*. Our years of experience in the radio shipping field are at your command without obligation.

**TIFFT BROS.**  
8 Broadway, New York City

*Shipping Cases for Difficult Problems*

# NEW AERO CHOKE COILS

## The Aero Choke 60

Modern circuits of high sensitivity demand the use of radio frequency chokes in certain parts of the circuit. The Aero Choke-60 is designed to have a uniform choking action over a wide range of wave lengths, including Broadcast bands and Amateur Short Wave bands as well. Many chokes employed on short waves have an unpleasant characteristic of showing so-called "holes" in the tuning range, which is present also on the broadcast band but in a minor degree. These faults are corrected in the Aero Choke 60. Price, \$1.50.



## The New Aero Choke 248

The Aero Choke 248 is especially designed for operation in Aero Transmitter kits 2040K, 4080K, and 9018K, and other circuits. Aero Choke 248 presents a high impedance or choking action over the usual amateur wave lengths. It is wound with a conductor sufficiently liberal to handle transmitters up to 100 Watts. Price, \$1.50.



**AERO PRODUCTS, Inc.**  
Dept. 17  
1772 Wilson Ave., Chicago, Ill.



# TIN FOIL

**FOR CONDENSERS**

*All grades of*  
TIN FOIL  
LEAD FOIL  
COMPOSITION FOIL  
ALUMINUM FOIL

**UNITED STATES FOIL CO.**  
LOUISVILLE . . . KENTUCKY

# WIRE

STRAND—Antennae (plain or enameled)—Double Galvanized.  
WIRE—Antennae (plain or enameled) Connecting and Ground (Rubber) covered, braided or plain.  
BUS BAR—Litzendraht-Loop.  
MAGNET (Cotton or Silk).

**John A. Roebling Son's Co.**  
Trenton, N. J.

**BETTER THAN THE BEST**      **NEW**      **CHEAPEST IN THE END**

**A New Tube Contact Spring Par Excellence**

Another achievement by Aurora. Over half million sold in short time.

Only one white top insulated eyelet required to mount. Contact effected between white and black make prong holes stand out in the dark.

Impossible to misalign, bind or spring in an inoperative position. Point of support directly on line of pressure when inserting tube.

Why not get in line with the leaders who use the best. They cost less than the cheap kind.

*Write or wire for samples and prices.*



**AURORA ELECTRIC CO.,**  
14-18 Dunham Pl.,      Brooklyn, N. Y.

**The LOGICAL Filament Control**



**AMPERITE**  
The "SELF-ADJUSTING" Rheostat

AMPERITE is not a fixed resistor or so-termed filament ballast. It is the only self-variable tube filament control—insuring just the proper filament current for each and every tube automatically. Does away with all rheostats on panel. Simplifies wiring and operation. Precludes tube damage from under or excessive "A" current, increasing tube life and always guaranteeing maximum tube performance. It is therefore indispensable.

*We co-operate with dealers and custom builders.*

**Radiall Company**  
50 Franklin St., New York, N. Y.

**LACQUERS**  
FOR THE  
**RADIO INDUSTRY**

**The Egyptian Lacquer Manufacturing Co.**  
Dept. R. E.  
90 West St., New York City

**RACON**      EXPONENTIAL SOUND CHAMBERS



No. 320  
Air Column 78 inches  
Bell 10" x 20"  
Depth 13½ inches  
*A size to fit every cabinet*

**Racon Electric Company, Inc.**  
18 Washington Place, New York, N. Y.

**Engineers**  
**Research Workers**  
**Set Builders**

—do you wish to know why AEROVOX FILTER CONDENSERS are accepted as standard?  
We'll tell you—We'll give you FACTS

Three samples tested at 1000 cycles

Cap.	Eff. Res.	Insul. Res.	Power Factor
No. 1. 1 mfd	.7 ohm	5000 meg p mfd	.44%
No. 2. 1 mfd	1.1 ohm	5000 meg p mfd	.69%
No. 3. 1 mfd	.9 ohm	4000 meg p mfd	.57%

Three samples tested at 60 cycles

No. 1. 1 mfd	*	*	*	305%
No. 2. 1 mfd	*	*	*	.426%
No. 3. 1 mfd	*	*	*	.392%

Do these figures convince you that you protect yourself when you use AEROVOX FILTER CONDENSERS? —The tests mentioned were made at the Bakelite Corporation Research Laboratories.

AEROVOX FILTER CONDENSERS are non inductive—use 100% pure linen paper dielectric—sections are individually impregnated in pitch to preclude moisture absorption.

Write to us — we will gladly mail additional engineering literature.

**AEROVOX**  
"Built Better"

70 Washington Street, Brooklyn, N. Y.

**New**  
**AMPLION**



Balanced Armature Units—for air-column or Cone

*They embody many impressive new features to insure quality in any set.*

1. Diaphragm with point of application off center to reproduce successfully, high and low frequencies.
2. Straight bar magnets of finest English tungsten steel — the most efficient type of construction.
3. Armature pivotted sturdily to insure permanent efficiency.

*Our Engineering Staff is always at the disposal of Set Manufacturers.*

**THE AMPLION CORPORATION OF AMERICA**  
531-535 West 37th Street, New York City

# Buyers Directory of Equipment and Apparatus

Readers interested in products not listed in these columns are invited to tell us of their wants, and we will inform the proper manufacturers. Address Readers' Information Bureau.

Addresses of companies listed below, can be found in their advertisements—see index on page 1022.

- ADAPTERS:**  
Bakelite Corp.  
Carter Radio Co.
- AMMETERS**  
Jewell Elec. Inst. Co.  
Westinghouse Elec. & Mfg. Co.
- AMPLIFIERS, RESISTANCE:**  
De Jur Products Co.  
Polymet Mfg. Co.
- ANTENNAE, LAMP SOCKET**  
Electrad, Inc.
- ARRESTERS, LIGHTNING:**  
Bakelite Corp.  
De Jur Products Co.  
Electrad, Inc.  
Jewell Elec. Inst. Co.
- BASES, VACUUM TUBE:**  
Bakelite Corp.  
Zierick Machine Wks.
- BATTERIES, DRY:**  
National Carbon Co., Inc.
- BINDING POSTS:**  
Bakelite Corp.  
X-L Radio Labs.
- BOXES, PACKING:**  
Tift Bros.
- BRACKETS, ANGLE:**  
Zierick Machine Wks.
- BRASS:**  
Copper and Brass Research Ass'n.
- CABINETS, METAL:**  
Van Doorn Co.
- CELLS, PHOTOELECTRIC:**  
Burt, Robert C.
- CHOKES, AUDIO FREQUENCY:**  
National Co.  
Samson Electric Co.
- CHOKES, RADIO FREQUENCY:**  
Cardwell, Allen D., Mfg. Co.  
General Radio Co.  
Samson Electric Co.
- CHOKES, B ELIMINATOR:**  
Dongan Elec. Mfg. Co.  
General Radio Co.  
National Co.  
Samson Electric Co.
- CLAMPS, GROUND:**  
Aurora Electric Co.
- CLIPS, SPRINGS:**  
Aurora Electric Co.
- COILS, CHOKE:**  
Dudlo Mfg. Co.
- COILS, IMPEDANCE:**  
Dudlo Mfg. Co.
- COILS, INDUCTANCE:**  
Aero Products, Inc.  
Dresner Radio Mfg. Co.  
Hammarlund Mfg. Co.  
National Co.  
Samson Electric Co.  
Precision Coil Co., Inc.
- COILS, MAGNET:**  
Dudlo Mfg. Co.
- COILS, RETARD:**  
Aero Products Co.  
Hammarlund Mfg. Co.
- COILS, SHORT WAVE:**  
Aero Products Co.  
Hammarlund Mfg. Co.  
Precision Coil Co., Inc.
- COILS, TRANSFORMER:**  
Dudlo Mfg. Co.
- CONDENSERS, BY-PASS:**  
Concourse Elec. Co.  
Electrad, Inc.  
Polymet Mfg. Corp.
- CONDENSERS, FILTER:**  
Aerovox Wireless Corpn.  
Concourse Elec. Co.  
Polymet Mfg. Co.
- CONDENSERS, FIXED:**  
Aerovox Wireless Corpn.  
Cardwell, Allen D., Mfg. Co.  
Concourse Elec. Co.  
Electrad, Inc.  
Polymet Mfg. Corp.
- CONDENSERS, MIDGET:**  
Cardwell, Allen D. Mfg. Co.  
Hammarlund Mfg. Co.
- CONDENSERS, MULTIPLE:**  
Cardwell, Allen D. Mfg. Co.  
Hammarlund Mfg. Co.  
United Scientific Laboratories.
- CONDENSERS, VARIABLE TRANSMITTING:**  
Cardwell, Allen D. Mfg. Co.  
Hammarlund Mfg. Co.
- CONDENSERS, VARIABLE:**  
Cardwell, Allen D. Mfg. Co.  
General Radio Co.  
Hammarlund Mfg. Co.  
National Co.  
Samson Electric Co.  
United Scientific Laboratories  
X-L Radio Laboratories.
- CONNECTORS:**  
Saturn Mfg. & Sales Co.
- CONTROLS, ILLUMINATED:**  
National Co.
- COPPER:**  
Copper & Brass Research Ass'n.
- CURRENT CONTROLS, AUTOMATIC:**  
Radlall Co.
- DIALS:**  
Bakelite Corp.  
General Plastics, Inc.  
National Co.
- DIALS, DRUM**  
Hammarlund Mfg. Co.  
United Scientific Laboratories
- DIALS, VERNIER:**  
National Co.
- ELIMINATORS, B BATTERY:**  
Dongan Elec. Mfg. Co.  
General Radio Co.  
National Co.  
Samson Electric Co.
- ELIMINATORS, UNITS FOR:**  
Dongan Elec. Mfg. Co.  
General Radio Co.  
Samson Electric Co.
- FILAMENT CONTROLS, AUTOMATIC:**  
Radlall Co.
- FOIL:**  
U. S. Foil Co.
- GALVANOMETERS:**  
Jewell Elec. Inst. Co.
- GETTER MATERIAL**  
Independent Laboratories, Inc.
- GRID LEAKS:**  
Aerovox Wireless Corpn.  
De Jur Products Co.  
Electrad, Inc.  
Lynch, Arthur H. Co.  
Polymet Mfg. Corp.
- HEAD SETS:**  
Bakelite Corp.
- HORNS, MOLDED:**  
Bakelite Corp.
- IMPEDANCE UNITS, TUNED DOUBLE:**  
K. H. Radio Laboratories.
- INDUCTANCES, TRANSMITTING:**  
Aero Products, Inc.
- INSTRUMENTS, ELECTRICAL:**  
Jewell Elec. Inst. Co.
- INSULATION, MOULDED:**  
Bakelite Corp.  
General Plastics, Inc.  
Westinghouse Elec. Mfg. Co.
- JACKS:**  
Aurora Elec. Co.  
Carter Radio Co.  
Electrad, Inc.  
Union Radio Co.
- JACKS, TIP:**  
Carter Radio Co.  
Union Radio Co.
- KITS, LOUDSPEAKER:**  
Engineers Service Co.  
Powertone Co.
- KITS, RECEIVER:**  
Daven Radio Corp.  
(Bass Note)  
Hammarlund-Roberts, Inc.  
(H-Q)  
K-II Radio Labs., Inc.  
(Amplifiers)  
Lynch, Arthur H., Inc.  
(Aristocrat)  
United Scientific Laboratories.  
(Pierce-Aero)
- KITS, SHORT WAVE:**  
Aero Products, Inc.
- KITS, TESTING:**  
Jewell Elec. Inst. Co.
- KITS, TRANSMITTING:**  
Aero Products, Inc.
- KNOBS:**  
Bakelite Corp.
- LACQUER:**  
Egyptian Lacquer Co.  
Zapon Co., The
- LABORATORIES:**  
Electrical Testing Labs.
- LEAD-INS:**  
Aurora Electric Co.  
Electrad, Inc.,
- LOCK WASHERS:**  
Shakeproof Lock Washer Co.
- LUGS:**  
Aurora Electric Co.  
Zierick Machine Wks.
- METERS:**  
Jewell Elec. Inst. Co.  
Westinghouse Elec. & Mfg. Co.
- MOUNTINGS, RESISTANCE:**  
Aurora Electric Co.  
Electrad, Inc.,
- NAME PLATES:**  
Crown Name Plate & Mfg. Co.
- NUTS:**  
Shakeproof Lock Washer Co.
- PACKING:**  
Tift Bros.
- PANELS, COMPOSITION:**  
Bakelite Corp.  
Van Doorn Co.  
Westinghouse Elec. & Mfg. Co.
- PANELS, METAL:**  
Crowe Nameplate Co.
- PAPER, CONE SPEAKER:**  
Seymour Co.
- PLUGS:**  
Bakelite Corp.  
Carter Radio Co.  
De Jur Products Co.  
Polymet Mfg. Co.

**POTENTIOMETERS:**

Carter Radio Co.  
Central Radio Laboratories.  
Electrad, Inc.  
United Scientific Laboratories.  
Ward Leonard Electric Co.

**RESISTANCES, FIXED:**

Aerovox Wireless Corp.  
Carter Radio Co.  
Central Radio Laboratories.  
Daven Radio Corp.  
De Jur Products Co.  
Electrad, Inc.  
Hardwick, Field, Inc.  
Lynch, Arthur H. Co.  
Polymet Mfg. Corp.  
Ward Leonard Electric Co.

**RESISTANCES, VARIABLE:**

American Mechanical Labs.  
Carter Radio Co.  
Central Radio Laboratories.  
Daven Radio Corp.  
De Jur Products Co.  
Electrad, Inc.  
Hardwick, Field, Inc.  
Polymet Mfg. Corp.  
Ward Leonard Electric Co.

**RHEOSTATS:**

Carter Radio Co.  
Central Radio Laboratories.  
De Jur Products Co.  
Electrad, Inc.  
Polymet Mfg. Corp.  
United Scientific Laboratories.

**SCHOOLS, RADIO:**

National Radio Institute.

**SHIELDING, METAL:**

Copper and Brass Research Assn.  
Crowe Nameplate Co.  
Van Doorn Co.  
Zierick Machine Wks.

**SOCKETS, TUBE:**

Bakelite Corp.

**SOLDER:**

Chicago Solder Co. (Kester).  
Silva Products, Inc.  
Westinghouse Elec. & Mfg. Co.

**SPEAKERS:**

Amplion Corp. of America.  
Engineers Service Co.  
Temple, Inc.

**STAMPINGS, METAL:**

Zierick Machine Wks.

**STRIPS, BINDING POST:**

X-L Radio Laboratories.

**SUBPANELS:**

Bakelite Co.  
Westinghouse Elec. & Mfg. Co.

**SWITCHES**

Aurora Electric Co.  
Carter Radio Co.  
Electrad, Inc.,

**TAPPERS**

Eastern Tube and Tool Co.

**TESTERS, B-ELIMINATOR:**

Jewell Electrical Inst. Co.

**TESTERS, TUBE:**

Jewell Elec. Inst. Co.

**TESTING INSTRUMENTS:**

Jewell Elec. Inst. Co.  
Westinghouse Elec. & Mfg. Co.

**TESTING KITS:**

Jewell Elec. Inst. Co.

**TESTING LABORATORIES:**

Electrical Testing Labs.

**TOOLS**

Eastern Tube and Tool Co.

**TRANSFORMERS, AUDIO:**

Dongan Elec. Mfg. Co.  
Ferranti, Ltd.  
General Radio Co.  
K. H. Radio Laboratories.  
Radiart Laboratories Co.  
Samson Electric Co.

**TRANSFORMERS, B-ELIMINATOR:**

Dongan Elec. Mfg. Co.  
General Radio Co.  
K. H. Radio Laboratories.  
Samson Electric Co.

**TRANSFORMERS, FILAMENT HEATING:**

Dongan Elec. Mfg. Co.  
General Radio Co.  
Samson Electric Co.

**TRANSFORMERS, OUTPUT:**

Dongan Elec. Mfg. Co.  
General Radio Co.

**TRANSFORMERS, POWER:**

Dongan Elec. Mfg. Co.  
Ferranti, Ltd.  
General Radio Co.  
National Co.  
Samson Electric Co.

**TRANSFORMERS, R. F., TUNED:**

Cardwell, Allen D. Mfg. Co.

**TUBES, A. C.:**

Arcturus Co.  
Armstrong Elec. & Mfg. Co.  
C. E. Mfg. Co.

**TUBES, RECTIFIER:**

Arcturus Co.  
Armstrong Elec. & Mfg. Co.  
C. E. Mfg. Co.  
Eureka T. and M. Co.  
Q. R. S. Company, The.

**TUBES, VACUUM:**

Arcturus Co.  
Armstrong Elec. & Mfg. Co.  
C. E. Mfg. Co.  
Eureka T. and M. Co.  
Q. R. S. Company, The.

**UNITS, SPEAKER:**

Amplion Corp. of America.

**VOLTMETERS, A. C.:**

Jewell Elec. Inst. Co.  
Westinghouse Elec. & Mfg. Co.

**VOLTMETER, D. C.:**

Jewell Elec. Inst. Co.  
Westinghouse Elec. & Mfg. Co.

**WASHERS:**

Shakeproof Lock Washer Co.

**WIRE, ANTENNA:**

Dudlo Mfg. Corp.  
Roebling, J. A., Sons, Co.

**WIRE, BARE COPPER:**

Acme Wire Co.  
Roebling, J. A., Sons, Co.

**WIRE, COTTON COVERED:**

Dudlo Mfg. Corp.

**WIRE, ENAMELED COPPER:**

Dudlo Mfg. Corp.

**WIRE, LITZENDRAHT:**

Acme Wire Co.  
Dudlo Mfg. Corp.

**WIRE, PIGTAIL:**

Dudlo Mfg. Corp.

**WIRE, SILK COVERED:**

Dudlo Mfg. Corp.

**WIRE, TINNED COPPER:**

Dudlo Mfg. Corp.  
Roebling, J. A., Sons, Co.

## 4 Adjustable "B" Voltages

In any combination from 0 to 180



Type 445

Price \$55

## The New General Radio Plate Supply

Embodying new and distinctive features in plate supply design

1. Adjustable wire wound resistance with sliding taps which control voltages so that any combination of voltages from 0 to 180 may be taken from the four positive "B" terminals. This method of voltage control is superior to the use of several resistances with exterior knob controls. It has the advantage that once the sliding taps are adjusted to the proper operating voltages of the tubes, they are tightened in place by thumb screws and voltages will remain constant, but are immediately available for readjustment whenever the unit is used with a different set.
2. Adjustable "C" voltage for power tube.
3. High voltage test condensers in filter circuit.
4. Uses UX-280 or CX-380 rectifier tube which has maximum output of 100 milliamperes, thereby providing sufficient current for sets of the multi-tube type.
5. Automatic cut-out switch breaks the 110 volt A. C. circuit when cover is removed for adjusting voltages or connecting wires to taps, thereby making unit absolutely safe even in the hands of persons not familiar with electrical apparatus.
6. Designed to meet the specifications adopted by the National Board of Fire Underwriters.
7. Absolutely guaranteed against mechanical and electrical defect upon leaving the General Radio factory.

Cost, which has been a secondary consideration to over-all efficiency has been kept as low as peak performance and production economies permit.

Price from your dealer, or direct from the factory if your dealer cannot supply you.

Type 445 Plate Supply Unit .....\$55.00

Type UX-280 or CX-380 Rectifier Tube  
for above ..... 5.00

Licensed by the Radio Corporation of America only for Radio Amateur, Experimental and Broadcast Reception.

Under terms of R. C. A. license unit may only be sold with tube.

## General Radio Company, Cambridge, Mass.

*Write today  
for your copy of*  
**“Copper Shielding for Radio”**

This new book shows how to improve the reception of your set. There is no charge.

Copper shielding means greater selectivity and sensitivity.

**COPPER & BRASS  
RESEARCH ASSOCIATION**  
25 Broadway, New York

# Bakelite Tapping SOLVED!

The ETTCO High Speed Tapping Attachment will tap a good thread in BAKELITE as well as other materials. If you are experiencing trouble try one out for 10 days.



ETTCO Tappers eliminate tap breakage, whatever the cause. A “green” operator can bang the bottom of a tapped hole using an ETTCO and still not break the tap—he has no friction to adjust.

Where ETTCO Tappers have been installed tap breakage has been eliminated and production increased 100 to 500%.

No. 1. ETTCO Tapper  
Capacity 1/4-inch  
No. 2. ETTCO Tapper  
Capacity 3/8-inch

Try an ETTCO TAPPER for ten DAYS. No obligation for the Trial.

**Eastern Tube & Tool Co.,** 600 Johnson Ave.,  
BROOKLYN, N. Y.

## INDEX OF ADVERTISERS

A	PAGE	E	PAGE	P	PAGE
Aero Products, Inc.....	1018	Egyptian Lacquer Co.....	1019	Polymet Mfg. Corp.....	1013
Aerovox Wireless Corp.....	1019	Electrad, Inc. ....	1018	Powertone Elec. Co.....	1014
Algonquin Elec. Co.....	1006	Electrical Testing Labs.....	1012	Precision Coil Co.....	1014
American Mechan. Labs.....	964	Engineers' Service Co.....	1012	Professional Directory.....	1012
Amplion Corp. of America.....	1019	Eureka T. & M. Co.....	1011	Q	
Arcurus Radio Co.....	1009	Experimenter Pub. Co.....	1015	Q. R. S. Music Co.....	1011
Armstrong Electric Co.....	1011	F		R	
Anrora Electric Co.....	1019	Ferranti, Inc. ....	1006	Racon Electric Co.....	1019
B		G		Radiall Corp. ....	1019
Bakelite Corp.....	Back Cover	General Plastics, Inc.....	965	Radiart Labs. Co.....	1016
Dr. Robert C. Burt.....	1006	General Radio Co.....	1021	Roebling, J. A. Son's Co.....	1018
Buyers Directory .....	1020-1021	H		S	
C		Hammarlund Mfg. Co.....	1003	Samson Elec. Co.....	997
Cardwell Allen D. Mfg. Corp.	Inside Front Cover	Hammarlund-Roberts, Inc.....	1012	Seymour Paper Co.....	1018
C-E Mfg. Co.....	966	Hardwick-Field Co.....	1007	Shakeproof Lock Washer Co....	1024
Central Radio Laboratories.....	1003	Howard, A. U. Co.....	1011	Shure Radio Co.....	1016
Chicago Solder Co.....	1024	I		T	
Citizens Radio Call Book Co....	1017	Independent Laboratories .....	1011	Temple, Inc.....	1003
Concourse Elec. Co.....	1023	J		Thor Radio Co.....	1016
Copper and Brass Research Assn.	1022	Jewell Elec. Inst. Co.....	1007	Tift Bros. ....	1018
D		K		U	
De Jur Products Co.....	997	K.-H. Radio Laboratories.....	1014	United Scientific Labs.....	1007
Dongan Elec. Mfg. Co.	Inside Back Cover	L		United States Foil Co.....	1018
Dressner Radio Mfg. Corp.....	1014	Lynch, Arthur H.....	1006	V	
Dudlo Mfg. Co.....	961	M		Van Doorn Co., The.....	1023
E		Miller-Welles Co.....	1016	W	
Eastern Tube & Tool Co.....	1022	N		Ward Leonard Elec. Co.....	1023
		National Carbon Co., Inc.....	963	X	
		National Co., Inc.....	1006	X-I. Radio Labs.....	1016
		Natl. Radio Inst.....	1001	Z	
				Zapon Co.....	997



# To Radio Manufacturers

Who plan to increase production at once

The Ward Leonard Electric Company manufactures a complete line of electrical control apparatus.

If you plan to expand present departments or add others, get in touch with our engineering department. They are at your service.

**Direct Current Motor Starters**  
Counter E. M. F. Type  
Bulletin 65

**Armature Speed Controllers**  
Fractional h. p. Fully Enclosed Type  
Bulletin 58

**Direct Current Motor Starters and Controllers**  
Bulletin 59

**Alternating Motor Starters and Controllers**  
Bulletin 64

**Circuit Breakers**  
Bulletin 61

Ward Leonard also manufactures Vitrohm Resistance Boxes, Sliding Contact Rheostats and other apparatus for laboratory use.

**Ward Leonard Electric Company**  
31-41 South Street,  
Mount Vernon, New York

CONCOURSE



Condenser Unit (unmounted)

CONDENSERS

**CONTRACT WORK EXCLUSIVELY**

The Concourse Electric Co. devotes their entire time and energy in assisting manufacturers to meet special condenser conditions. We are Fixed Condenser Specialists. Today we are serving 95 per cent of those manufacturers we served two, three and even four years ago. That speaks of one thing—Satisfactory Service. Our Engineering Department solicits the opportunity of working with your staff in meeting exacting requirements.

**CONCOURSE ELECTRIC COMPANY**  
294 East 137th St., New York, N. Y.

CONCOURSE



Condenser Assembly for 350 to 400 Mil. Series Wired Power Sets

CONDENSERS

# Vee Dee

## All-Metal Cabinet— For 1927-1928 Hook-Ups!

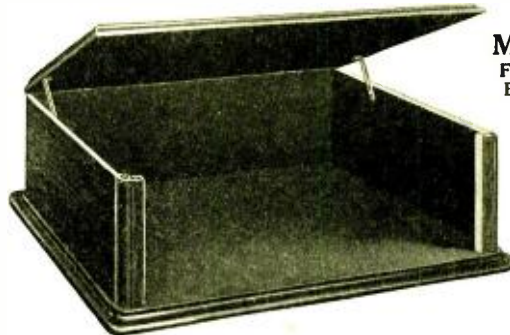

**Model 250**  
For A. C. or Battery Sets

Using  
7x18  
7x21  
8x18  
8x21  
Panels

Inside dimensions 25"x14 1/4"x9 1/4". Hinged top—with stay joint. Rigidly formed for strength and appearance. Felt foot rests—rubber lid stops. A welded job doing away with troubles of swelling, shrinking, cracking, splitting and the uncertain fit of wood cabinets.

The original beauty of natural wood grains combined with the efficiency of all metal construction! By our photo litho process, we reproduce mahogany and walnut hardwood, and novelty finishes, so gorgeous in their conception that they excite the admiration of all who see them.

Spacious interior dimensions are demanded for housing all the latest hook-ups! Vee Dee metal cabinets are designed for that purpose. 90% of all the 1927-1928 hookups are covered by the dimensions of Vee Dee No. 250 cabinet illustrated above. Beautiful—practical! Low price!



### Metal Panel for Citizens Super Eight

Constructed in accordance with Citizens Radio Call Book and McMurdo Silver, Remler, Cockaday co-ordinated designing



### Metal Panel and Chassis for Silver-Marshall Improved Shielded LAB Model Receiver

Complete assembly consisting of panel and chassis, fully drilled, beautiful wood finish with special two-color decoration, all fibre bushings and washers included, also screws, bolts and hardware accessories.

### S. C. 2 Assembly Unit

Complete panel, chassis, 7x18—fully drilled. Wood grain finish, beautifully decorated. Kit includes all necessary bushings, washers and accessories.



### Unipac Housing

Especially designed and provided for Silver-Marshall Power Hook-ups—including cabinet and chassis, drilled and with all small hardware. Inside dimensions, 17 1/2" long, 5 3/4" high.

Metal Panels and Chassis in All Standard Sizes

**JOBBERS, DEALERS—WRITE FOR PRICES**

Set Builders—If your dealer cannot supply you, write direct

## The Van Doorn Company

160 North La Salle Street

Factory, Quincy, Illinois

Chicago, Illinois

## SPECIAL LOW PRICES

on  
*plain lug terminals*



Type 1  
50c per M

(Prices in lots of 5M or over)



Type 2  
60c per M

An order recently received from one of the large radio manufacturers enables us to offer attractive prices on the terminals illustrated.

They are made of the highest quality tinned brass, eighteen thousandths thick. Free samples for the asking.

**And here's a SHAKEPROOF terminal made especially for riveting!**

**Positively**  
**will not turn,**  
**twist or**  
**wiggle loose—**  
**and it costs no more!**



Type 21  
a brass locking lug terminal.

*Should you want to try these terminals before ordering, we shall be glad to submit free samples.*

**SHAKEPROOF**  
**Lock Washer Company**

2511 North Keeler Avenue, Chicago

Division Illinois Tool Works

**The right flux for radio**  
*can make a manufacturer*  
**The wrong flux**  
*can quickly break him*

After costly experiments scores of radio manufacturers have found there is but one safe flux for radio soldering—rosin.

Rosin, an organic mixture, is a non-conductor and non-corrosive. The glass-like surface of this material does not readily lend itself to the collection of dust (carbon particles) as will the sticky organic greases or paste. Nor will rosin attract moisture from the atmosphere; the chlorides of pastes and fluids will. *Moisture plus carbon particles defeat the best insulations produced. Moisture plus chlorides direct a slow but determined corrosive attack upon supporting metals.* Such slow corrosion in wiring causes a steadily increasing resistance to the flow of electrical energy.

Kester Rosin-Core Radio Solder scientifically combines radio's premier flux, rosin, with a solder alloy of unvarying quality. The use of Kester Radio Solder furnishes the user with a means of accomplishing *safer, faster and cleaner* set wiring.

Manufacturers using Kester Rosin-Core Solder are assured that no part of their production will ever be returned or fall into discard through the corrosive and conductive action of a chloride flux.

Our experimental and research laboratory has assisted many manufacturers in the solving of their soldering problems. A post card will bring you further information without obligation.



**KESTER SOLDER**  
*Rosin-Core*

CHICAGO SOLDER COMPANY  
4224 Wrightwood Avenue, Chicago, U. S. A.

Originators and  
World's Largest Manufacturers of Self-fluxing Solder



## The Newest ABC Power Supply Unit

- used with R C A 226 and 227 A C Tubes
- Raytheon BH Tube

This latest development of the Dongan laboratories combines in one small, compact metal case the essential transformers and chokes designed for use with R C A 226 and 227 A C Filament Tubes (also UX 171 power amplifier tube) and the Raytheon BH Rectifier Tube. Complete power supply is secured—eliminating the need of batteries and charger. The new R C A 226 and 227 A C tubes likewise take the place of standard 201 A tubes.

Simplified, assured and consistent power at all times—from the light socket. Convenience, eventual economy and improved radio reception—the ultimate aim of all fans achieved at last.

For complete information write to Dongan laboratories. If your dealer cannot supply you send check or money order direct.

No. 5552



ABC Power Supply Unit  
used with  
R C A 226 and 227 tubes  
and  
Raytheon BH tube  
\$20.00 list

No. 4586



Low Voltage Transformer  
used with  
R C A 226 and 227 tubes  
\$8.00 list

### Manufacturers

You may have the cooperation of our engineering department at any time. All approved parts (transformers and chokes) for power supply factors are in production now.

Write for details.

**DONGAN ELECTRIC MANUFACTURING COMPANY**  
2995-3001 Franklin St.  
DETROIT, MICHIGAN





*Tuning Coils with Bakelite Molded Parts. Made by Bruno Radio Corporation, Long Island City, N. Y.*

## A manufacturer produces an improved part at one-half former cost

**T**HROUGH using Bakelite Molded, the Bruno Radio Corporation were able to improve the design and appearance of their tuning coils and increase their durability. In addition, finishing and drilling operations were eliminated, production increased, and cost reduced fifty per cent.

This case is typical of the experience of the majority of radio parts manufacturers, and explains why Bakelite Molded

has become the premier insulation for radio devices.

### *Bakelite Engineering Service*

Bakelite Sales and Service Engineers are located in important industrial centers throughout the country, and they are equipped to render prompt and helpful cooperation to present and prospective users of Bakelite Materials. The Bakelite Corporation places at their service the facilities of its extensive laboratories, and its unequalled experience in the practical application of phenol resin products to the requirements of the radio industry.

Write for Booklet 38 "Bakelite Molded"

### **BAKELITE CORPORATION**

247 Park Ave., New York, N.Y. Chicago Office, 635 W. 22nd St.

**BAKELITE CORPORATION OF CANADA, LTD.**, 163 Dufferin St., Toronto, Ont.

# BAKELITE

REGISTERED



U. S. PAT. OFF.

THE MATERIAL OF A THOUSAND USES

"The registered Trade Mark and Symbol shown above may be used only on products made from materials manufactured by Bakelite Corporation. Under the capital "B" is the numerical sign for infinity, or unlimited quantity. It symbolizes the infinite number of present and future uses of Bakelite Corporation's products."